

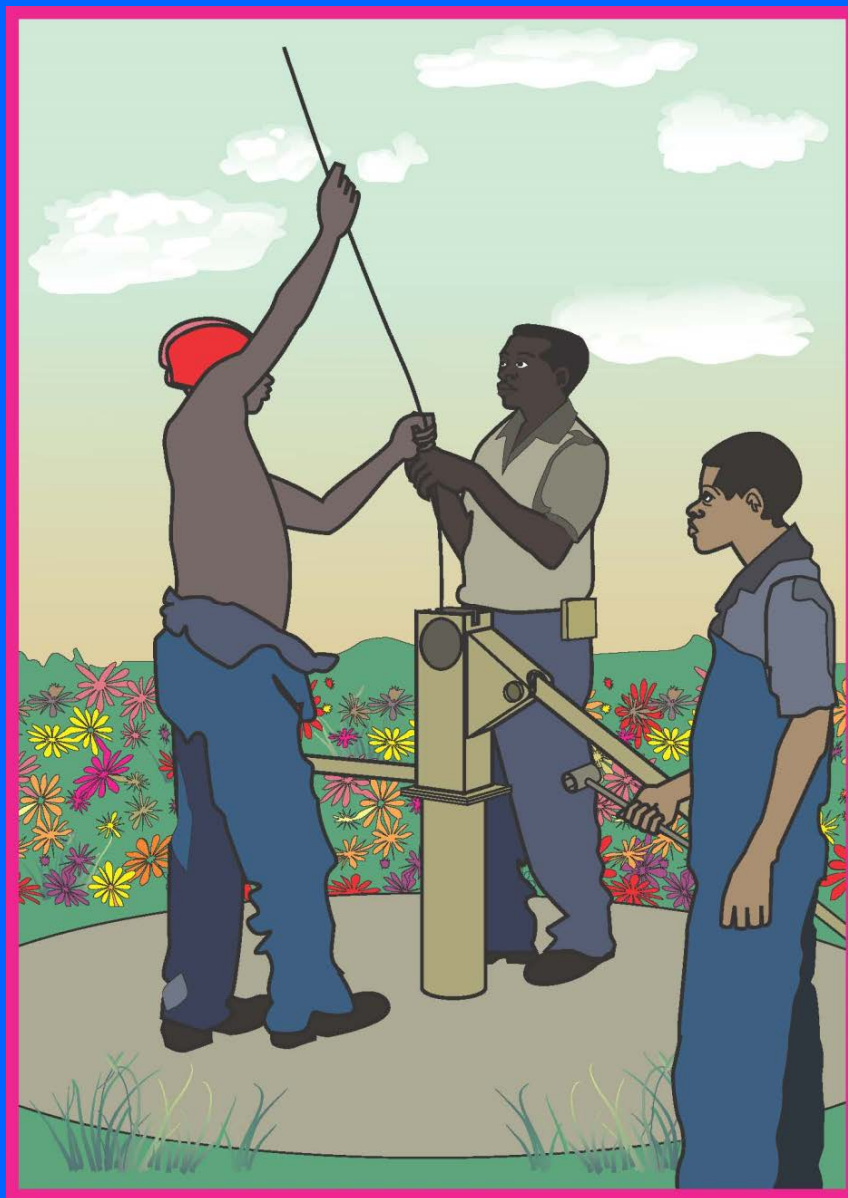

Government of Malawi

Rural Water Supply Operation and Maintenance Series 4

Training Manual for Area Mechanics



Ministry of Agriculture, Irrigation and Water Development

March 2015



Rural Water Supply Operation and Maintenance Series 4

Training Manual for Area Mechanics

Ministry of Agriculture, Irrigation and Water Development

March 2015

Ministry of Agriculture, Irrigation and Water Development
Tikwere House,
City Centre,
P/Bag 390,
Lilongwe 3,
Malawi
Telephone No.: (265) 1 770 211 / 770 233 / 770 344 / 770 447
Fax No.: (265) 01 773 737
E-mail: secretary@irriwater.org

Date of publication: March 2015

87 p

Rural Water Supply Operation and Maintenance Series 4

This document was published by Ministry of Agriculture, Irrigation and Water Development (MoAIWD) of Malawi with the technical and financial support of the Japan International Cooperation Agency (JICA) through the “Project for Enhancement of Operation and Maintenance for Rural Water Supply in the Republic of Malawi”.

The copyright of this document shall exclusively remain with MoAIWD and JICA (MoAIWD and JICA are hereinafter referred to as the “copyright holders”). The copyright holders allow anyone to use this document as long as it is used for the purpose of public good. Any parts of this document including the illustrations may be copied to meet local needs without permission from the copyright holders, provided that the copies are

- (a) distributed for free and used for the good of people;
- (b) not used for profit making;
- (c) referred with the source of information.

For making any modifications, reprinting and/or using any part of the document for commercial purposes, please ask permission of the copyright holders at the following contacts;

Director of Water Supply Services
Ministry of Agriculture, Irrigation and Water Development

Country Representative of JICA Malawi Office
Telephone No: (265) 01 771 554 / 644 / 945

Table of Contents

PREFACE	vi
ACKNOWLEDGEMENTS	vii
OVERVIEW OF THE TRAINING MANUAL	viii
Chapter I: Training Contents	1
Section 1: Introduction to the training of Area Mechanics	1
1.1 Objective of the AM training	1
1.2 Background to Community Based Management (CBM)	1
1.3 Difference between caretaker's repair skill and AM's repair skill	3
1.4 Duties of an area mechanic	3
Section2: Necessary software skills for area mechanics.....	5
2.1 Building trust with the community	5
2.2 Conflict management and problem solving.....	5
2.3 Business management	7
2.4 Understanding contract conditions	8
2.5 Promotion activities.....	10
2.6 Water Point Sanitation	11
Section3: Afridev hand pump parts and function	13
Section4: Dismantling and reassembling pump.....	18
4.1 Tools for dismantling and reassembling pump	18
4.2 Dismantling	18
4.3 Reassembling	20
Section 5: Trouble shooting and diagnosis of Afridev hand pumps	23
5.1 Trouble shooting	23
5.2 Identify fast wearing parts and their effects in pump operation.....	32
5.3 Identification of problems in the rising main	32
Section 6: Repairing rising main.....	33
6.1 Removing and replacing of the rising main	34
6.2 Repairing of the rising main.....	35
6.3 Making joints on the rising main.....	36
Section 7: Regular preventive maintenance checks	40
7.1 Identification of problems in an Afridev hand pump	40
7.2 Leakage test.....	42
7.3 Discharge test	43
7.4 Records.....	43
7.5 Fishing.....	44

Chapter II Training Module.....	45
Module 1: Initial training for Area Mechanics.....	45
Session No. 1 (M1-S1)	47
Session No. 2 (M1-S2)	49
Session No. 3 (M1-S3)	51
Session No. 4 (M1-S4)	53
Session No. 5 (M1-S5)	54
Session No. 6 (M1-S6)	56
Session No. 7 (M1-S7)	58
Session No. 8 (M1-S8)	60
Session No. 9 (M1-S9)	62
Module 2 Refresher training for Area Mechanics.....	64
Session No. 1 (M2-S1)	65
Session No. 2 (M2-S2)	66
Session No. 3 (M2-S3)	68
Session No. 4 (M2-S4)	69
Chapter III Training Timetable.....	71
Timetable for Area Mechanic Initial Training (Draft)	71
Timetable for Area Mechanic Refresher Training (Draft).....	73
Appendices	75
Appendix 1: Sample form for contract.....	76
Appendix 2: AM Monitoring Checklist.....	77

LIST OF ABBREVIATIONS

ADC	Area Development Committee
AM	Area Mechanic
CBM	Community Based Management
CDA	Community Development Assistant
DWDO	District Water Development Officer(r)
EWs	Extension workers
GITEC	German International Technical Cooperation
HSA	Health Surveillance Assistant
HTH	High Test Hypochlorite
MAIWD	Ministry of Agriculture, Irrigation, and Water Development
NGO	Non-governmental Organization
O&M	Operation and maintenance
PVC	Poly Vinyl Chloride
UNICEF	United Nations children Fund
VDC	Village Development Committee
WMA	Water Monitoring Assistant
WPC	Water Point Committee

PREFACE

Access to clean drinking water remains a priority for Malawi's development, and the establishment of a well-functioning Area Mechanic system is a leading approach for achieving this goal. While Water Point Committees (WPC) are encouraged to take ownership over their water point and most have received Community Based Management (Training), they lack the technical skills for executing advanced repairs of their hand pump. Meanwhile, the District Water Development Office does have those technical skills, but do not have adequate resources for reaching and repairing every water point within the district in a timely manner. Thus, Area Mechanics (AM) – locally trained, artisans in advanced hand pump repair operating on a payment basis – can provide important repair services at community level.

In order to play this role effectively, AMs must be equipped with a variety of skills and tools. Not only must they have the required technical skills for executing advanced repairs, but they must also be able to build trust with the community and provide reports to the DWDO.

This training manual details both the initial training that should be conducted for the AM as well as the subsequent training for refreshing the skills of the AM. It covers both what is needed in terms of software skills and technical skills and both the content as well as the facilitation notes for each section of the training.

The training of Area Mechanics is a crucial step in providing ongoing service delivery of operation and maintenance to water points and this document is thus an invaluable document in achieving that. Any substantive comments for improvement on the manual are welcome and should be directed to the secretary responsible for water development.



Sandram C. Y. Maweru

SECRETARY FOR IRRIGATION AND WATER DEVELOPMENT

ACKNOWLEDGEMENTS

This manual was produced by the “Project for Enhancement of Operation and Maintenance for Rural Water Supply in the Republic of Malawi” under the technical cooperation by Japan International Cooperation Agency (JICA).

A series of workshops were held in the project, and a lot of stakeholders in Malawi, development partners, and NGOs technically contributed in the formulation of the manual. The Ministry of Agriculture, Irrigation and Water Development therefore, extends special thanks to these stakeholders for allowing their staff to participate in the production of this manual.

The Ministry is also indebted to JICA for assisting in the development of the manual, and many who have not been mentioned here but contributed in different ways.

Overview of the training manual

This manual details the course to be used for training area mechanics (AMs). This course can be given as initial training to newly recruited AMs and/or as refresher training to active AMs.

This training manual is compiled¹ from several attempts by stakeholders in the field of operation and maintenance of hand pumps, i.e. InterAide, UNICEF and GITEC.

The manual has been arranged in such a manner that it covers seven sections in five (5) days. The sections are as follows:

- Section 1: Introduction to the training of area mechanics
- Section 2: Necessary software skills for Area Mechanics
- Section 3: Afridev hand pump parts and function
- Section 4: Dismantling and reassembling pumps
- Section 5: Trouble shooting and diagnosis on Afridev hand pumps
- Section 6: Repairing rising main
- Section 7: Regular preventive maintenance checks

The training contains the following two modules

- **Module 1: Initial training for area mechanics**
 - Session 1: Introduction to the training of area mechanics
 - Session 2: Necessary software skills for area mechanics
 - Session 3: Afridev hand pump parts and function
 - Session 4: Dismantling and reassembling pumps
 - Session 5: Trouble shooting and diagnosis on Afridev hand pumps
 - Session 6: Repairing rising main
 - Session 7: Repairing rising main by participants
 - Session 8: Regular preventive maintenance checks
 - Session 9: Question and answer session on technical aspects of the training, materials/tools related to area mechanic activities, spare parts procurement
- **Module 2: Refresher training for area mechanics**
 - Session 1: Introduction and climate setting
 - Session 2: Community approach refreshed
 - Session 3: Introduction of new technology on the Afridev hand pump and/or lecture of repair techniques of the other type of hand pumps

¹Sources of information:

1. Installation and Maintenance Manual for the Afridev Hand pump Revision 2- 2007, SKAT-RWSN
2. AREA MECHANIC TRAINING CONTENT by InterAide
3. DRAFT TRAINING MANUAL FOR AREA MECHANICS by UNICEF
4. AFRIDEV HANDPUMP ADVANCED REPAIR MANUAL FOR AREA MECHANICS (DRAFT) by GITEC
5. Community Handbook on Water and Sanitation, Afridev Version, Community Based Management Unit, Malawi Government, 1999

Session 4: Technical refreshment on the Afridev hand pump

This manual shall be used alongside the following materials:

- Section 4 Afridev Hand Pump Maintenance, Community Handbook on Water and Sanitation Afridev Version, Community Based Management Unit, Malawi Government, 1999

Chapter I: Training Contents

Section 1: Introduction to the training of Area Mechanics

1.1 Objective of the AM training

- To enable them to do complicated repairs on the water points (WP) and advise communities on maintaining the WP with the primary objective of increasing pump functionality.
- To help them understand that they are independent workers/ entrepreneurs paid by the community.

1.2 Background to Community Based Management (CBM)

Refresher training to remind area mechanics that CBM is fundamental to the operation & maintenance (O&M) for a hand pump.

a. What is CBM?

- Empowerment – the community controls things and makes their own decisions
- Sense of responsibility, commitment, and ownership by the community
- The community maintains the water point – if it breaks, they repair it
- Monitoring and evaluation to check that they are achieving results

b. How to build CBM

- Ask open ended questions to encourage them to talk, identify issues, find solutions, and make decisions
- Allow the community to solve their own problems, make decisions, hold their own meetings, organise activities and take action
- Don't be the "expert" – avoid telling the community members what to do

- Don't talk – be quiet and give the community members a chance to talk
- Listen to what people say and use their opinions to build further discussions
- Praise their contributions and show respect for their ideas to empower them to manage on their own
- Confident to manage any situation
- Build on their experience and their own history of organising things
- Work at a pace that can help to achieve the concept of CBM
- Summarise the discussion

c. CBM is about learning from the past experience

- Who implemented the project?
- Why did it work or fail?
- How was the project managed at the community level?
- What happened when the facility broke down?
- How was payment handled?
- What conflicts developed? And how were they resolved?

d. Problems with the community organisation

- Members are selected on the basis of favouritism, e.g., chief's friends or relatives
- Women and minority groups are left out of committees and decision making
- Domination by a few people (e.g., chairman, secretary) who make all the decisions
- Low levels of initiative & responsibility – they tend to wait for outsiders to tell them what to do
- Few meetings – they meet only when the water point breaks down or when there is a project
- Money is poorly handled and recorded – there are some cases of misappropriation
- Lack of accountability so the community has no trust in the committee
- Roles of members not followed

- Drop outs not being replaced
- Facilities working without WPCs

e. Indicators of strong CBM

- Sense of ownership of facility by community members, e.g., not allowing the misuse of their facilities
- Elections of management committee using a democratic process when need arises
- Women are committee members and participate actively in decision making
- Regular and well attended meetings – both committee and community meetings
- Decision making by the whole committee, rather than just a few people
- Action planning, work shared among all members and checks on performed actions
- Money is properly collected, saved, recorded and used for correct purposes
- Accountability and transparency – regular reports to community on use of funds
- Good system for maintenance – such as quick action when the pump breaks down
- The whole community, not just caretakers, have interest in pump maintenance
- Whole community participates in communal action, e.g., maintaining of sanitary conditions of water point surrounding
- Good relations/networking with chief, VDC, and outside organizations
- Committee being in contract with AM

1.3 Difference between caretaker's repair skill and AM's repair skill

A caretaker's repair skill amounts to minor repairs to the WP, i.e. changing fast wearing parts whereas an AM has the repair skill to do major repairs e.g. reparation with rising main and making joints on it.

1.4 Duties of an area mechanic

In providing paid technical service to the communities, the area mechanic bears the following duties:

- Assist communities in repairing their WP

- Advise communities on good use of the WP
- Advise communities on keeping the WP surroundings clean at all times
- Promote Spare Parts Retail Shops by advising Water Point Committees (WPCs) on where to buy spare parts
- Report technical problems to the District Water Development Officer (DWDO) or Water Monitoring Assistant (WMA)
- Make monthly reports to the DWDO
- Keep relevant records including payments made by WPC
- Make quotation on water point maintenance costs
- Advise WPC on how to raise funds for WP maintenance
- He/she should promote himself/herself among the community
- He/she should attend ADC meetings when necessary
- He/she should take care of his/her repair tools

Section2: Necessary software skills for area mechanics

Area mechanics are supposed to have necessary software skills in order to perform their duties effectively.

2.1 Building trust with the community

a. How to enhance dialogue with the community

- AMs should be prepared to market themselves and not always expect community to come to them.
- AMs should learn how residents communicate among themselves, and then stay connected with people using their networks and groups
- They should identify values they share with the community
- Always be open, clear and honest with the communities. If you don't have an answer to their questions, let them know.
- Try to be always accessible. Meet with the community on a regular basis
- Be sensitive to cultural diversity. Understand that every culture sees issues differently

b. How to assure communities that you listen and will address their concerns

- Be clear about details
- Develop a public communications plan with active input from the community
- Keep good relationships with the community

2.2 Conflict management and problem solving

a. Managing difficult behaviour

a.1 Difficult behaviour can be responded to by applying the following techniques:

- Use of calm tone of voice and being 'ordinary' can help relax people. 'Let's go get something to drink and discuss it'

- Use of a calm, assertive statement about listening and trying to find an answer to the problem is a good way to go. 'Tell me what the problem is. Maybe together we can find a solution'
- Avoid blaming others, instead express your feelings
- Keep focused on the issue and avoid being side-tracked
- Do not try to change the person's mind by arguing or debating because a person who is angry is less likely to respond to logic or reason
- Avoid prejudgement

a.2 Things can be made worse by doing the following:

- Criticising or insulting people with 'you' messages. 'You are being really silly about this'
- Trying to make people feel guilty
- Insisting on supremacy of logical argument
- Interrogation
- Empty reassurance

a.3 The following are additional tactics to be taken into consideration:

- An angry person usually needs and benefits from more personal space
- Body language needs to match verbal language. A relaxed stance shows that a person is listening and is calm
- Eye contact shows interest and attention but staring can increase anxiety

b. Managing conflict

b.1 Conflict also has disadvantages and the following are some of them:

- People can become hurt
- People can become angry
- People can become confused
- It can be scary
- It can stop people taking risk

b.2 It is better to avoid conflict, however, sometimes conflicts can bring the following advantages:

- It brings about change
- Presents an opportunity to learn
- Encourages a person to do better
- Helps people to see and understand differences
- Helps people to become more flexible
- Removes doubts and helps people to move forward

b.3 The following problem-solving skills can be used when managing conflicts:

- Treat the person with respect
- Listen until you understand the other person's view
- State your feelings, needs and views briefly
- Move on to problem solving if required

c. Problem solving

c.1 When solving a problem, the following model should be applied:

- Define the problem: begin with wants. What does the other party want? Is it a big problem, it may need to be broken down into sub-problems that can be solved one at a time
- Brainstorm possible solutions: come up with as many solutions as possible without criticism or evaluation of the suggestions
- Evaluate the possibilities: go down the list of solutions, noting the pros and cons and probable consequences of each one. Write them down if it helps
- Select the solution: explore whether one solution emerges as the best option.

2.3 Business management

a. What is business

A business is any activity or work that one does with the aim of making a profit. The person who carries out or does business is called an entrepreneur or a business person. Area mechanics fall into this category. They provide services to the community. In turn they get paid for their services at a minimal profit

b. Characteristics of a good and successful AM as an entrepreneur

For area mechanics to succeed in their entrepreneurship, it is expected that they should have the following characteristics:

- Good organizational skills to negotiate their contracts with the community
- Has good objectives for doing business (i.e. helping the community accessing safe water)
- Has a good understanding of how to repair hand pumps and the implications attached to that activity
- Bold enough to take/meet risks attached to the repair of hand pumps and has confidence about succeeding
- Patience and persistence to achieve set objectives when executing the duties of AMs
- Maintains a good relationship with the WPCs and spare parts retail shops
- Good communication skills
- Considers the needs of the community
- Literate enough to write records and plans

c. Types of records to keep

The types of records to be kept by AMs are listed below:

- Contract with the WPCs
- Information, quotations and payment for repair

This shall be prepared in triplicate, one to be kept by the AM, one for the WPC and one for the District.

2.4 Understanding contract conditions

a. What is a contract?

The AMs activities are an important arm to support sustained O&M in the community. The activity provides technical service on the payment basis by a request from the community. A contract is a legal action approved by the agreement of both parties to provide a technical service.

b. Content to mention in the contract

The contract should mention at least the following contents clearly.

- Date of the contract
- An address and the name of the AM
- Condition of the contract

The condition of the contract should include at least the following contents.

- Type of the contract
- Term of the contract
- Contents of the repair and/or the maintenance
- Condition of the payment
- Signature of both parties

c. Type of contract

There are two types of standard contracts, Maintenance contract and Repair contract. The contracts should include the following information.

For details on the contract form, see a sample contract form found in **Appendix 1**.

Maintenance contract

This type of contract is for one year and the AM should visit the water point at least 4 times in a year for maintenance of the hand pump.

The fee for the contract is MK4,500 (as of 2014)

The fee of contract should be revised in consideration with current inflation rates.

The Area Mechanic should do assessments during every supervisory visit to a borehole under contract. The following monitoring checklist/card could be used as a guide for conducting minimum checks for each monitoring visit to a borehole.

Sample of the AM monitoring checklist (See Appendix 2)

Borehole number:	No.1					
Village Name :	Nzangawo					
T/A	Zulu					
District:	Mchinji					
Monitoring Data	1/1/2015					
Hand pump is working	Good	✓	Fair		Bad	
Grouting of pedestal or pump stand	Firm	✓	Loose			
No of strokes to fill 20L bucket (Appx. 40 to 50 strokes for well-functioning borehole)		Strokes 41 strokes				
Corrosion of pump stand and head	None	✓	Slight		Bad	
Corrosion of handle parts	None	✓	Slight		Bad	
Condition of plunger set-up	Good	✓	Fair		Bad	
Condition of foot valve set-up	Good	✓	Fair		Bad	
Worn out sealing parts	Bobbin	✓	O-ring		U-seal	✓
Worn out pump rods	None		Slight	✓	Bad	
Worn out rod centralizers	None		Slight	✓	Bad	
Worn out bush bearings	None		Slight	✓	Bad	
Wear on cylinder liner	None	✓	Slight		Bad	
Why poor performance/ breakdown	No spares		No funds	✓	No skill	
Name of Area mechanic	Mr. Pili					
Date	1/1/2015					
Signature	Pili					
Water point committee representative	Mr. Zimba					
Signature	Zimba					
Date	1/1/2015					

Source: Adopted from SKAT-RWSN 2007: Installation and Maintenance Manual for Afridev Hand pump

Repair contract

This type of contract is signed whenever there is a breakdown of the hand pump and the WPC has not signed the maintenance contract with the AM.

The fee of contract should be set at a standard price according to the type of repair.

2.5 Promotion activities

Awareness campaigns should be conducted by the District. The promotion of the new AM can be done through regular forums such as ADCs, or through additional promotion activities such as drama, etc.

At a minimum, awareness of AMs and their roles should be promoted by:

- Informing communities, WPCs, and other community structures (e.g. community police) of the AM in their area and what their role is.
- Spread awareness of AMs through the DWDO's other field activities or through other sectors such as health or education
- Invite AMs to CBM trainings and HSA staff meetings
- Optional promotion tools might include the following, if additional funds are available;
 - Business cards
 - Sign posts
 - T-shirts
 - Newsletters
 - Fliers
 - Radio
 - Drama productions
 - Map of catchment area with photos of AMs

2.6 Water Point Sanitation

Area Mechanics are in constant contact with the WPCs when they come to do repair or maintenance work. During this time AMs can play a crucial advisory role to the communities if they find that the WP surrounding is not sanitary. Two facilities that assist to improve sanitation at the water point are fences and soak away pits. Fences help to keep away animals that can cause contamination while soak away pits prevent the accumulation of water which can act as breeding places for germs.

2.6.1 Fences

- It is important to erect a good fence around water point. This can be done immediately after the construction of the well is finished and should give enough space to operate the hand pump. The advantages of fencing are that they define the area of the borehole to the community and they keep animals away from the well to prevent contamination of water source by animal faeces.
- There are different types of fences. Community members can choose the style of a fence based upon the availability of money they have, how often will they need to repair and style or design preferences. There are six types of fences communities can choose from: grass, timber, bamboo, plant, brick and brick with plaster

2.6.2 Soak away pits

- This is a drainage channel which can lead to a ditch or to existing surface water drainage systems: irrigation channels, cattle trough and sometimes evapotranspiration beds (where water is absorbed by plants)
- The functions of a soak away pit are to prevent unsightly and unhygienic condition of water point, to prevent water contamination at the point of source and to prevent breeding of mosquito at the site
- The size and design of soak away pit depends on the different types of soak away pit

Section3: Afridev hand pump parts and function

The assembly of the Afridev hand pump is shown in the following figure:

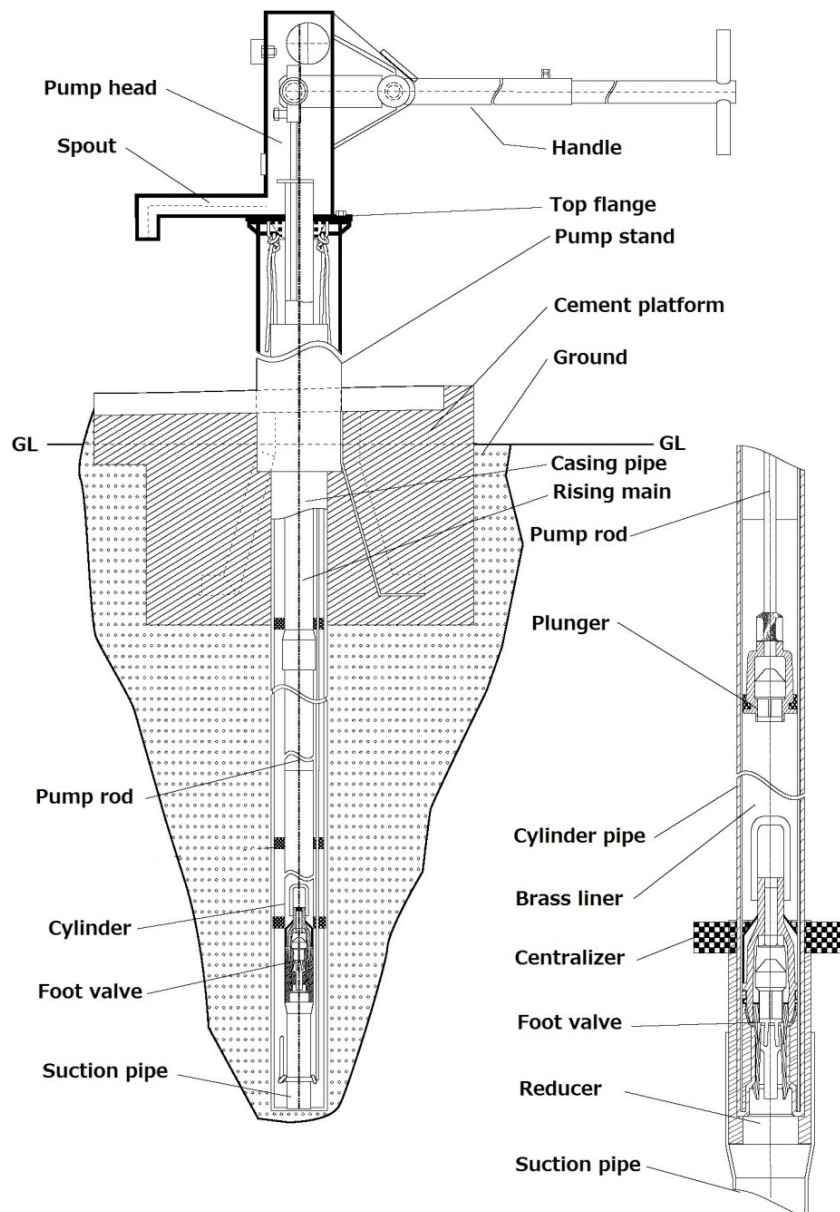

Figure 1: Afridev pump²





²This figure is modified based on the drawing No. D9021 of Installation and Maintenance Manual for the Afridev Hand pump Revision 2- 2007, SKAT-RWSN



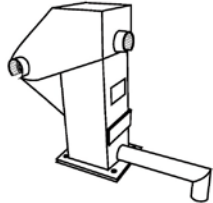
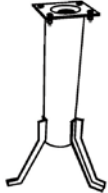
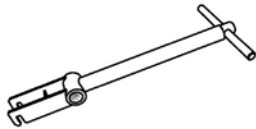

Afridev hand pump parts are divided into two categories “Above ground parts” and “Below ground parts”

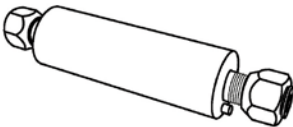
The names and functions of each spare part are given in the following table:

a. Above ground components

Table 1: Name and functions of each spare parts

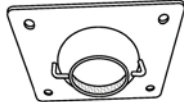





No.	COMPONENT	FUNCTION	ILLUSTRATION
	English / Chichewa		
1	Head pump and cover / Hedipampu chi vindikilo	Encloses the topmost part of the pump to prevent dust and foreign materials from getting inside the pump, it houses the hanger assembly and supports the handle bar	
2	Pump pedestal / Pampupedesitilo	Main body supporting above ground components and below ground components	
3	T/bar / handulo	This is the part that is held to pump water. It can be adjusted to correspond to the depth of the BH	
4	Hanger Assembly / Hang'aAsembule	Rods are suspended from this	
5	Fulcrum pin / Fakulamupini	Joins the handle bar to the head pump and acts as a movement joint for the handle pumping water	
6	Hanger pin / Hang'apini	Joins the end part of the handle to the hanger to allow for upward and downward movement of the rods	

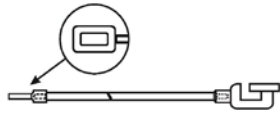
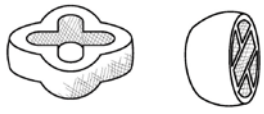
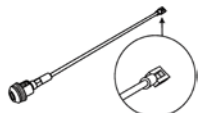

No.	COMPONENT	FUNCTION	ILLUSTRATION
	English / Chichewa		
7	Bush bearing / BushiBelingi	Allows free movement of the fulcrum pin and hanger pin. There are four in a pump, two on the fulcrum pin and two on the hanger pin	
8	Rubber flapper / LabalaFulapa	Installed on the top rod to prevent foreign materials from getting into the rising main and to prevent water from gushing out	
9	Rubber Cone / Labalakoni	Sits between the pump head and pedestal acts as a seal to stop water from spilling between the pump head and pedestal	
10	Steel cone plate / KoniPuleti	A metal plate holding the rising main	
11	Top sleeve(collar) / Topusilivi	It prevents the rising main from slipping through the rubber cone	

b. Below ground components

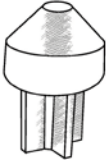
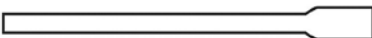
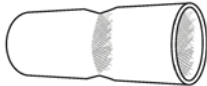
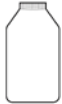
Table 2: Name and functions of each spare parts

No.	COMPONENT	FUNCTION	ILLUSTRATION
	English / Chichewa		
12	Pump rod / Pampurodi	To connect plunger so that the pump can be operated above the ground using the handle	
13	Rod Centralizer / RodiSentelelaiza	Fitted on rod joints to centralize rods and prevent friction between the rod and the rising main	
14	Plunger / Pulanja	Connected to pump rods; moves up and down with the movement of the handle to facilitate suction of and	

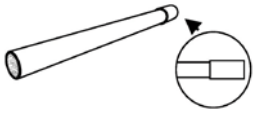
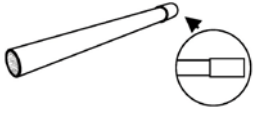
No.	COMPONENT	FUNCTION	ILLUSTRATION
	English / Chichewa		
		delivery of water	
15	Foot-Valve / FutuValavu	Keeps the pumped water from going back down the bore hole	
16	U-Seal / U-Silo	Fitted to the plunger body; seals water above plunger and pushes water up with every upward movement of the plunger (plastic plunger only)	
17	Cup-seal / Kapu-Silo	Fitted to the plunger body; seals water above plunger and pushes water up with every upward movement of the plunger (brass plunger only)	
18	O-ring / O-ring'i	Fitted to the foot valve to prevent water inside the cylinder from getting back into the bore hole	
19	Bobbin / Bobini	Fitted inside plunger and foot valve; moves up and down to allow water to move in one direction only and prevents water from getting back into the bore hole	
20	Rising main / Mapaipi	A pipe connected to cylinder assembly carries water from the cylinder to ground level	
21	Double end socket / Dabulosoketi	To join two rising mains after repairing (use solvent cement)	
22	Solvent cement / Soventisementi	To join two rising mains after repairing (use solvent cement)	
23	Rising main centraliser / Sentelelaiza wa ma paipi	Fitted every 3 meters, rising main prevents excessive swaying of the rising main in the borehole	

No.	COMPONENT	FUNCTION	ILLUSTRATION
	English / Chichewa		
24	Cylinder assembly / SilindaAsembule	Most important part of the pump, it draws water from the borehole and pumps it up to ground level	
25	Suction pipe / Sakishonipaipi	Fitted at the bottom end of the cylinder it draws water into the cylinder and controls sand intake	
26	Rope(nylon rope 6mm) / Chingwe	Connected to the suction pipe and passes through the pipe centralizer to the cone plate to hold the rising main from falling into the borehole in case of joint failure	



Section4: Dismantling and reassembling pump

4.1 Tools for dismantling and reassembling pump

Necessary tools for dismantling and reassembling Afridev hand pump are as follows:

- Socket spanner
- Flat spanner
- Fishing tool



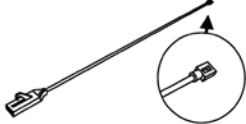

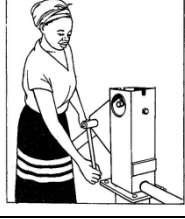
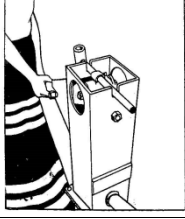

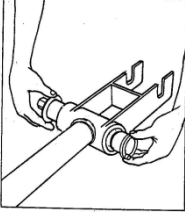
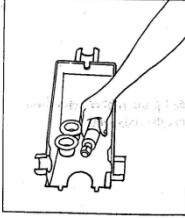
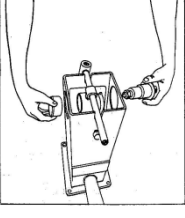

Table 3: Tools for dismantling and reassembling Afridev handpump





No.	COMPONENT	FUNCTION	ILLUSTRATION
	English / Chichewa		
1	Socket spanner 24 / Spanarayabowo	To remove head cover and to hold the hanger assembly when removing rods	
2	Flat spanner 17/19 / Spanarayafulati	To remove the bolts between head and pedestal	
3	Fishing tool / Mbedza	To fish the foot valve and pump rods	

4.2 Dismantling

Necessary steps for dismantling are described as follows:

Table 4: Necessary steps for dismantling

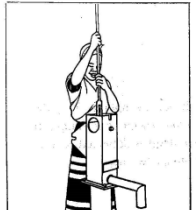
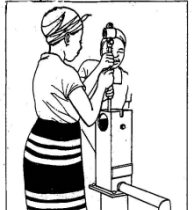
No.	Step	Illustration	No.	Step	Illustration
1	Before starting wash your hands and fill some buckets with water to allow you to clean the parts		2	Loosen the pump head cover bolt	
3	Take off the cover		4	Loosen both hanger nuts	
5	Loosen both fulcrum nuts		6	Put spanner through hanger eye.	
7	Raise and withdraw handle. Take care! As you remove the handle make sure that the bush bearings and pin do not fall out as they may break on the floor.		8	Remove fulcrum pin and bush bearings.	
9	Place all parts in the cover for safe keeping.		10	Remove hanger pin and bush bearings.	
11	Pull up the hanger and first rod.		12	Slide up the rubber centralizer where the rods join.	

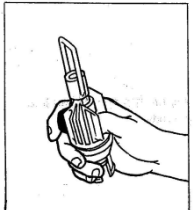
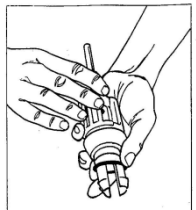
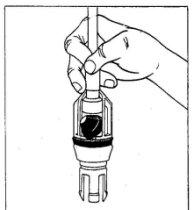
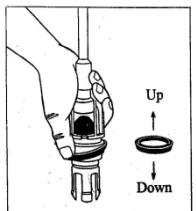





No.	Step	Illustration	No.	Step	Illustration
13	Disconnect and remove all the rods. Remember to keep the rods in the same order. The last rod taken out should be the first one put back.		14	Remove the plunger.	
15	Lower the fishing tool and join to the rods.		16	Gently lower last rod and hanger until you feel that you have caught the foot valve.	
17	Remove all the rods, fishing tool and foot valve.		18	Push out the bobbin from the foot valve with your thumb. If the bobbin is damaged replace it with a new one.	
19	Remove the O-ring from the foot valve. If the O-ring is damaged replace it with a new one.		20	Push out the bobbin from the plunger with your thumb. If the bobbin is damaged replace it with a new one.	
21	Carefully remove the U-seal. If the U-seal is damaged replace it with a new one. Make sure that the groove faces upwards.				



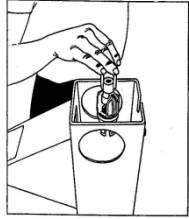

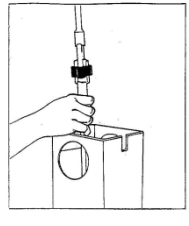
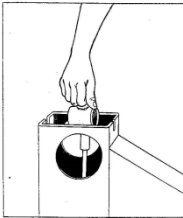
Source: SECTION 4 AFRICEV HANDPUMP MAINTENANCE, COMMUNITY HANDBOOK ON WATER AND SANITATION AFRIDEV VERSION

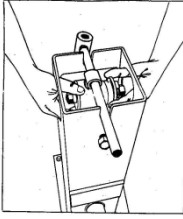
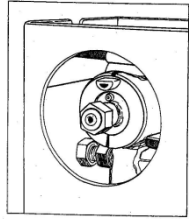
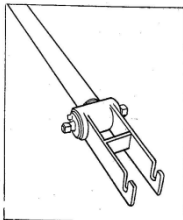
4.3 Reassembling

Necessary steps for reassembling are described as follows:

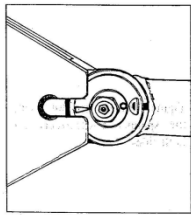
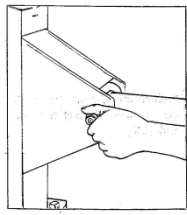
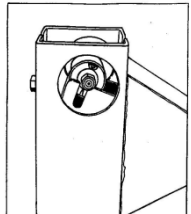
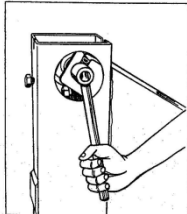
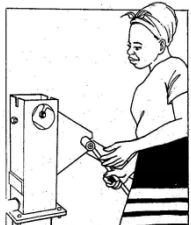
Table 5: Necessary steps for reassembling

No.	Step	Illustration	No.	Step	Illustration
1	Wash the foot valve, plunger and rods. Only use clean water.		2	To re-assemble the pump first drop the foot valve down the borehole. Make sure the hook is upwards.	
3	Put the plunger and pump rods back together and lower them down the borehole.		4	Make sure the rubber centralizer is slid down over each joint on the pump rods.	
5	Join all the rods together until the hanger rod is connected.		6	Make sure the foot valve is in place by pushing the rods at arm length down the borehole.	
7	Put the spanner through the hanger eye to support the rods and then replace the hanger pin and bush bearings. If the bush bearings are worn out or damaged then replace them with new ones.		8	Turn the hanger pin and bush bearings so that the small projecting lugs are at the top.	
9	Put back the fulcrum pin and bush bearings in the handle. If the bush bearings are worn out or damaged then replace them with new ones.		10	Put back the handle.	

No.	Step	Illustration	No.	Step	Illustration
11	Make sure the projection lugs on the pin and bush bearings will fit into slots on the pump body. Ensure that the pin is pushed right to the back of the slot.		12	Tighten the fulcrum nuts by hand.	
13	Push the handle down so that the slots engage in the hanger. Ensure that the hanger pin has slid to the bottom of the slots. Remove the spanner.		14	Tighten the hanger nuts with the spanner alternatively on both sides.	
15	Tighten the fulcrum nuts with the spanner alternatively on both sides.		16	Put back the cover.	
17	Tighten the cover nut.		18	Pump water until clean water comes out before using for drinking.	

Source: SECTION 4 AFRICEV HANDPUMP MAINTENANCE, COMMUNITY HANDBOOK ON WATER AND SANITATION AFRIDEV VERSION

Section 5: Trouble shooting and diagnosis of Afridev hand pumps

5.1 Trouble shooting

Identifying problems at the water point.

- 1 . No water?
- 2 . Delayed flow of water?
- 3 . Reduced discharge water?
- 4 . Water is turbid?
- 5 . Taste is salty? or water smells?
- 6 . Abnormal noise during operation?
- 7 . Pump handle is shaky?

Possible problems and remedies are outlined below.

Table 6: Trouble Shooting Chart

Problem	Possible case	Remedy	Degree of repairs [*] ₁
No water	1) Riser pipes are disconnected	1) Pull out complete rising main and repair/replace pipes	B
	2) Pump rods are disconnected	2) Pull out pump rods and replace broken and corroded rods	A
	3) Cap seal is defective	3) Replace cap seal	A
	4) Borehole is clogged (silt or sand)	4) Rehabilitation of boreholes	C
	5) Water level has dropped under the cylinder	5) Add riser pipes and pump rods	B
Delayed discharge water	6) Leaking of valve bobbins	6) Check and replace bobbins (plunger and foot valve)	A
	7) Leaking of foot valve O-ring	7) Replace O-ring	A
	8) Leaking in pipe joint or rising main is perforated	8) Pull out complete rising main and repair/replace pipes	B
Reduced discharge water	9) Cup seal is too tight	9) Replace with seal of correct size	A
	10) Borehole screen is clogged by incrustation	10) Rehabilitation of borehole (cleaning with compressed air or by bailing)	C

Problem	Possible case	Remedy	Degree of repairs* 1
	11) Full stroke is not possible	11) Check and adjust length of the top rod	B
	12) Cup seal is worn	12) Replace seal	A
	13) Leaking of valve bobbins	13) Check and replace bobbins (plunger and foot valve)	A
	14) Leaking of cylinder (cracked)	14) Pull out complete rising main and repair/replace cylinder (solvent cement joint)	B
Water is turbid	15) Accumulation by siltation becomes large	15) Rehabilitation of borehole (cleaning with compressed air or by bailing)	C
	16) Screen/casing pipes are torn	16) Rehabilitation of borehole (relining casing/screen pipes inside existing casing pipes, if possible)	C
Taste is salty or water smells	17) Sewage intrusion through cracks of platform/apron	17) Rehabilitation of platform	C
	18) Contamination through aquifer pathway	18) Check the distance from the pit latrine and abandon the pit latrine within a radius of 40m of the borehole	A
Abnormal noise during operation	19) Bearings are worn, handle fork touching the sides	19) Check and replace bearing sets (4)	A
	20) Pump rods are touching riser	20) Straighten or replace bent pump rods and replace worn rods	A
	21) Pump rods rubbing on riser pipes	21) Check and replace worn pump rod centralisers	A
	22) Pump rod centralisers worn	22) Check and straighten bent pump rods and replace worn rods	A
Pump handle is shaky	23) Pump platform is cracked	23) Repair pump platform	C
	24) Flanges are loose	24) Tighten all bolts and nuts of the flanges	A
	25) Bearings are worn	25) Check and replace bearing sets (4)	A
	26) Fulcrum pin is loose	26) Check fulcrum pin (and bearing sets) and tighten both nuts fully	A
	27) Hanger pin is loose	27) Check hanger pin (and bearing sets) and tighten both nuts fully	A

*1 Degree of repair;

A: Caretaker(s) of WPC can repair

B: It is recommended to ask Area Mechanic(s) to repair (highlighted by greycolor in above table)

C: It is recommended to ask Extension Worker(s) to repair

Table 7: Trouble shooting chart 1 (No water)

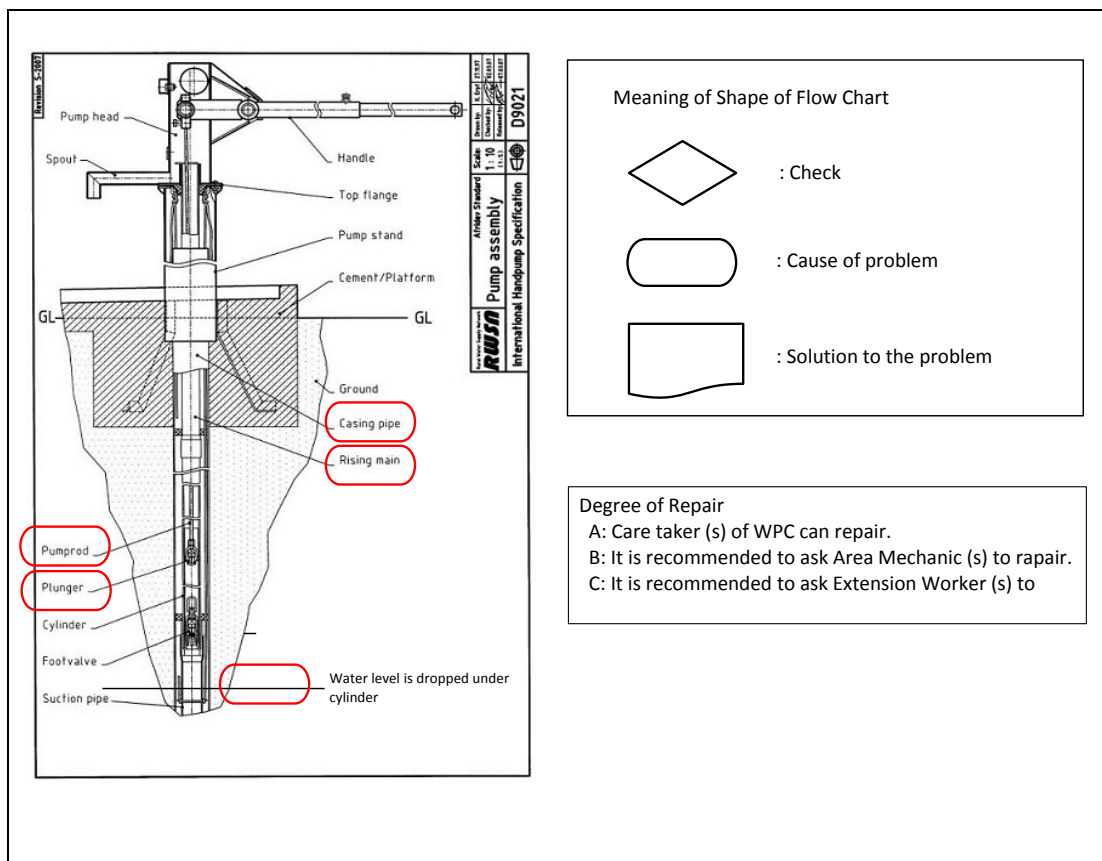
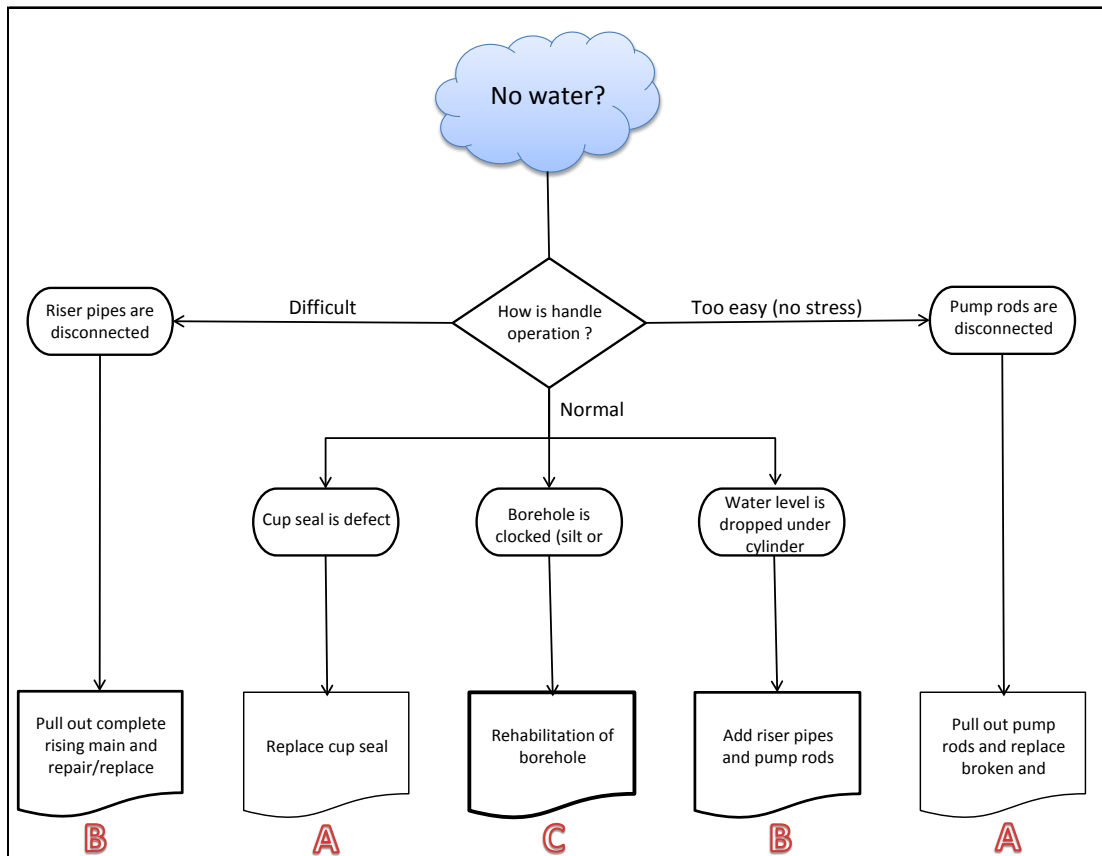

Table 8: Trouble shooting chart 2 (Delayed flow of water)

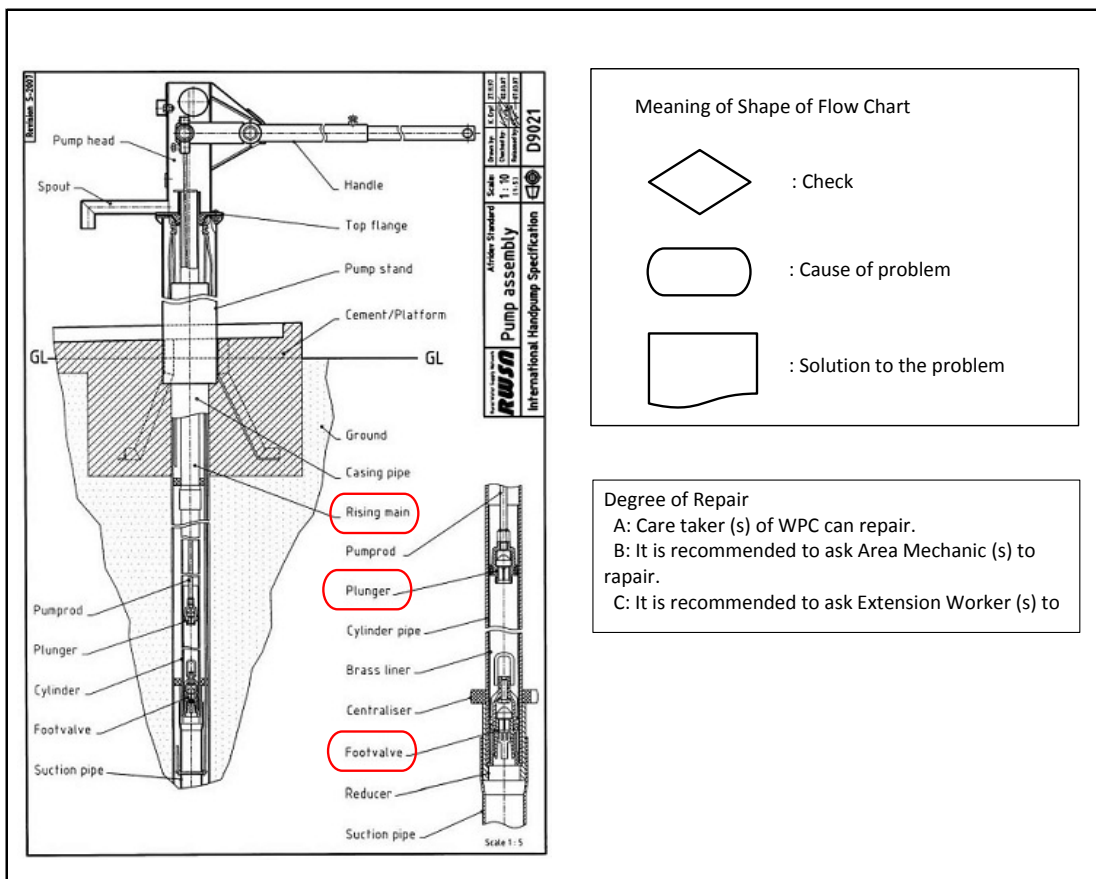
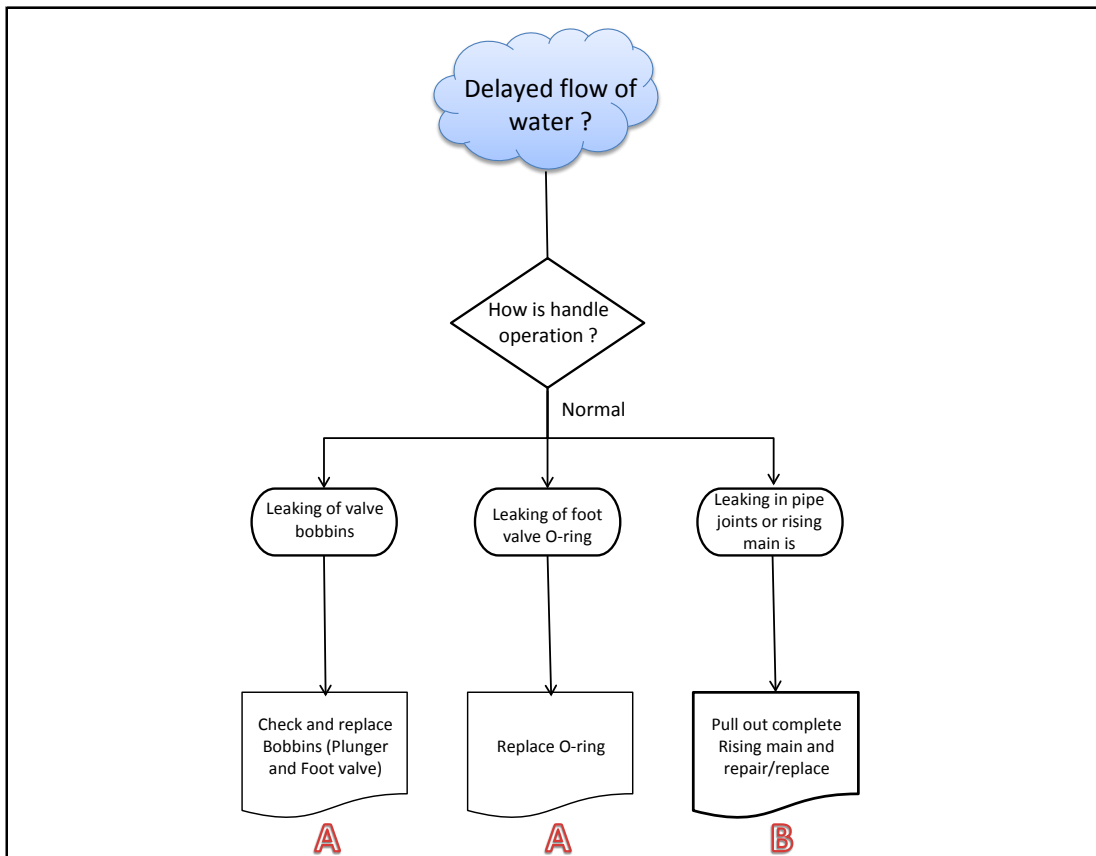

Table 9: Trouble shooting chart 3 (Reduced discharge water)

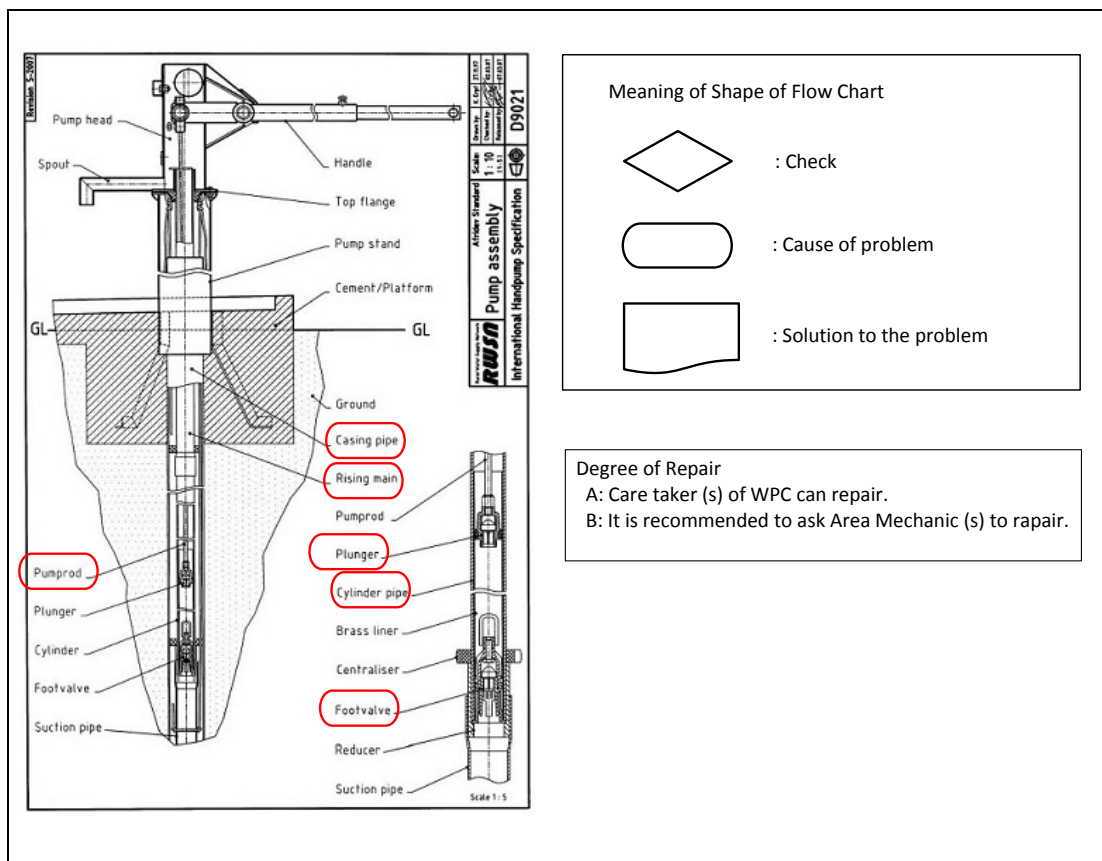
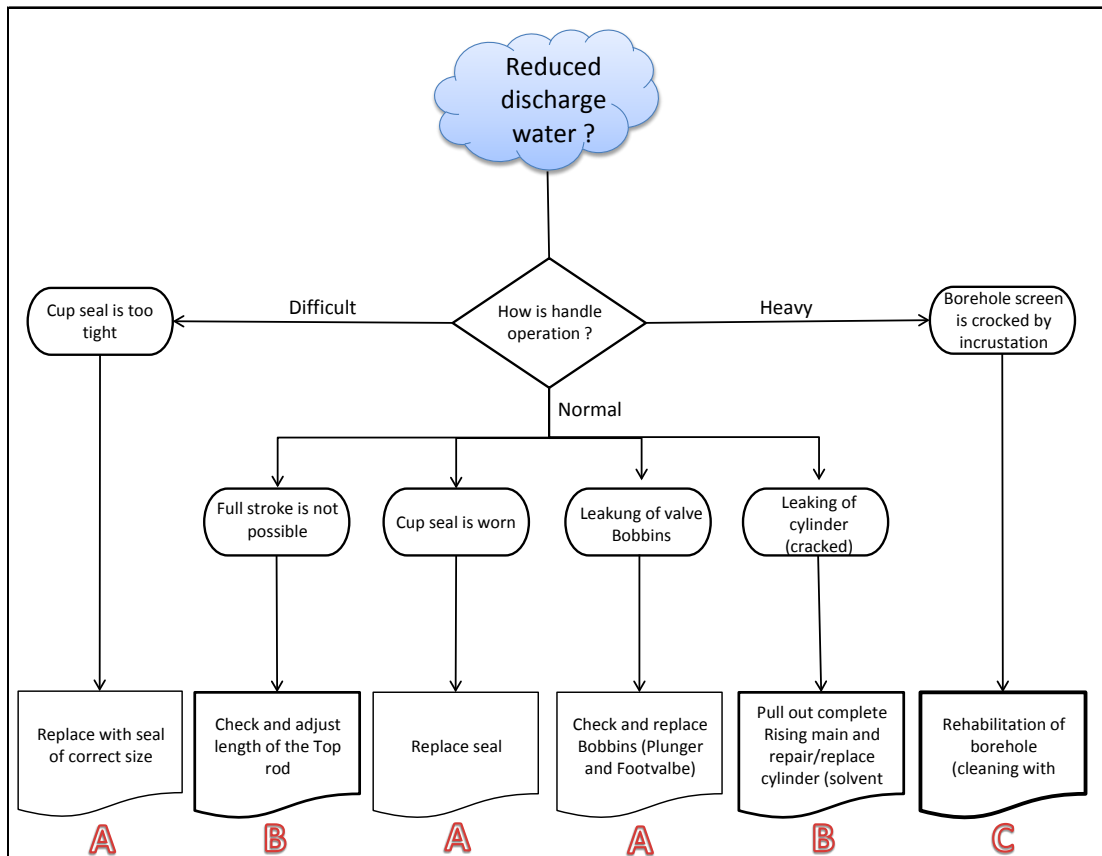

Table 10: Trouble shooting chart 4 (Water becomes turbid)

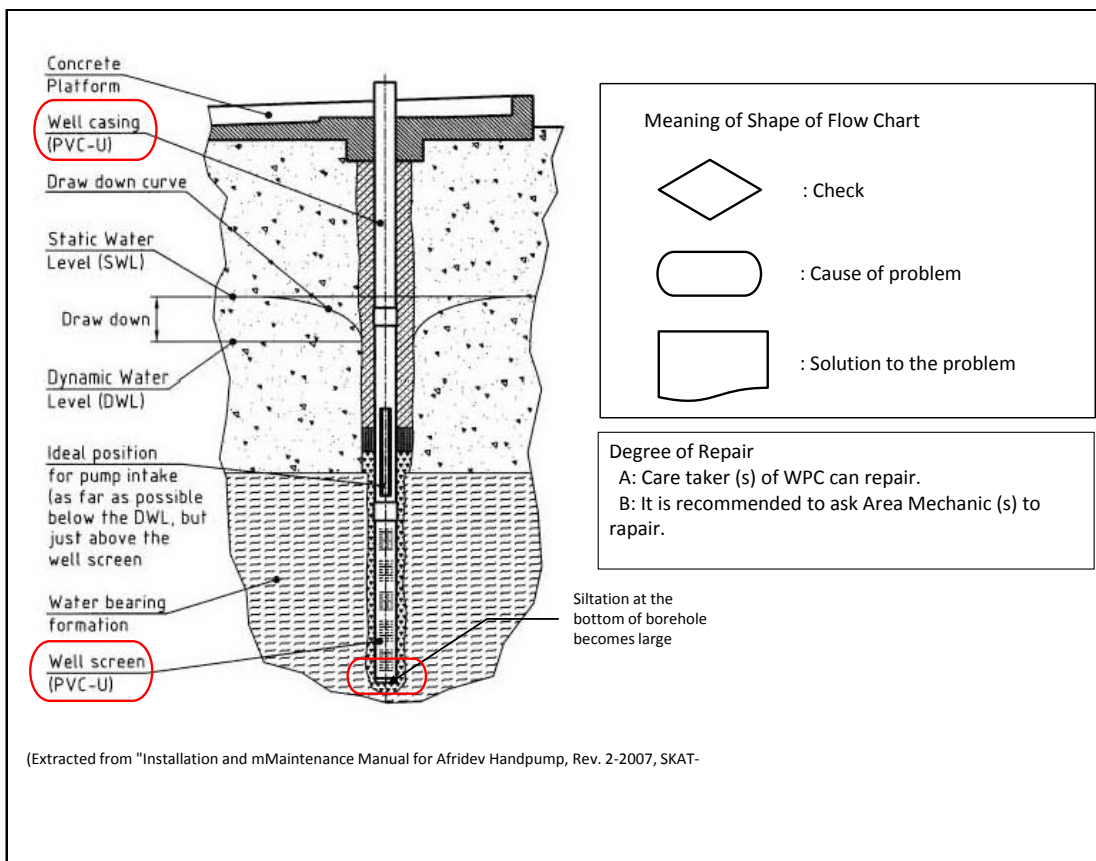
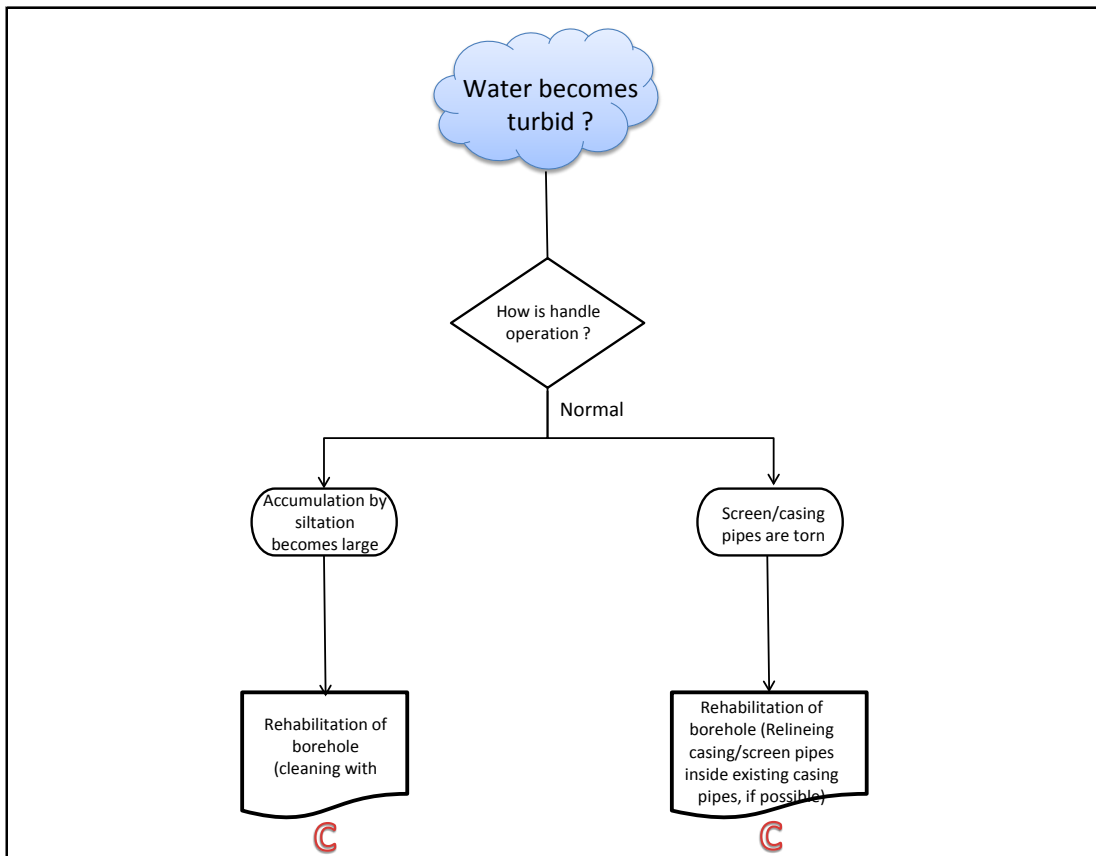

Table 11: Trouble shooting chart 5 (Taste becomes Salty or Water Smells)

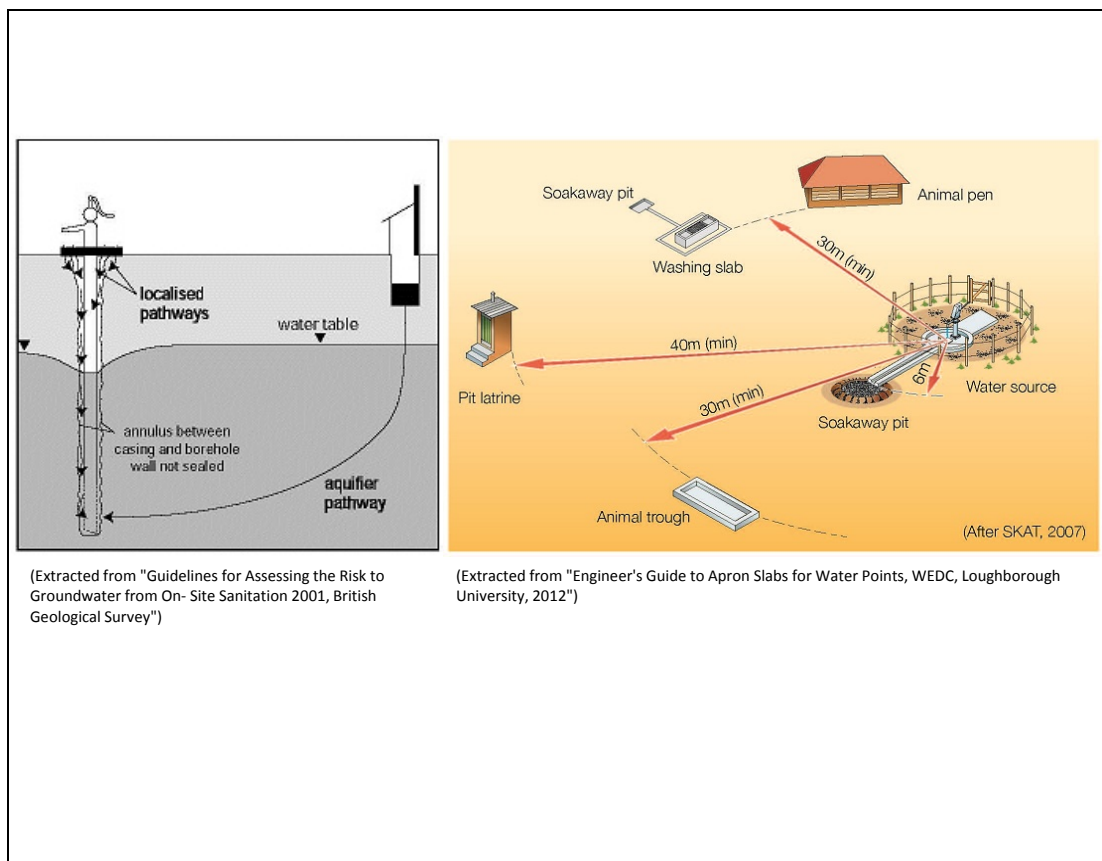
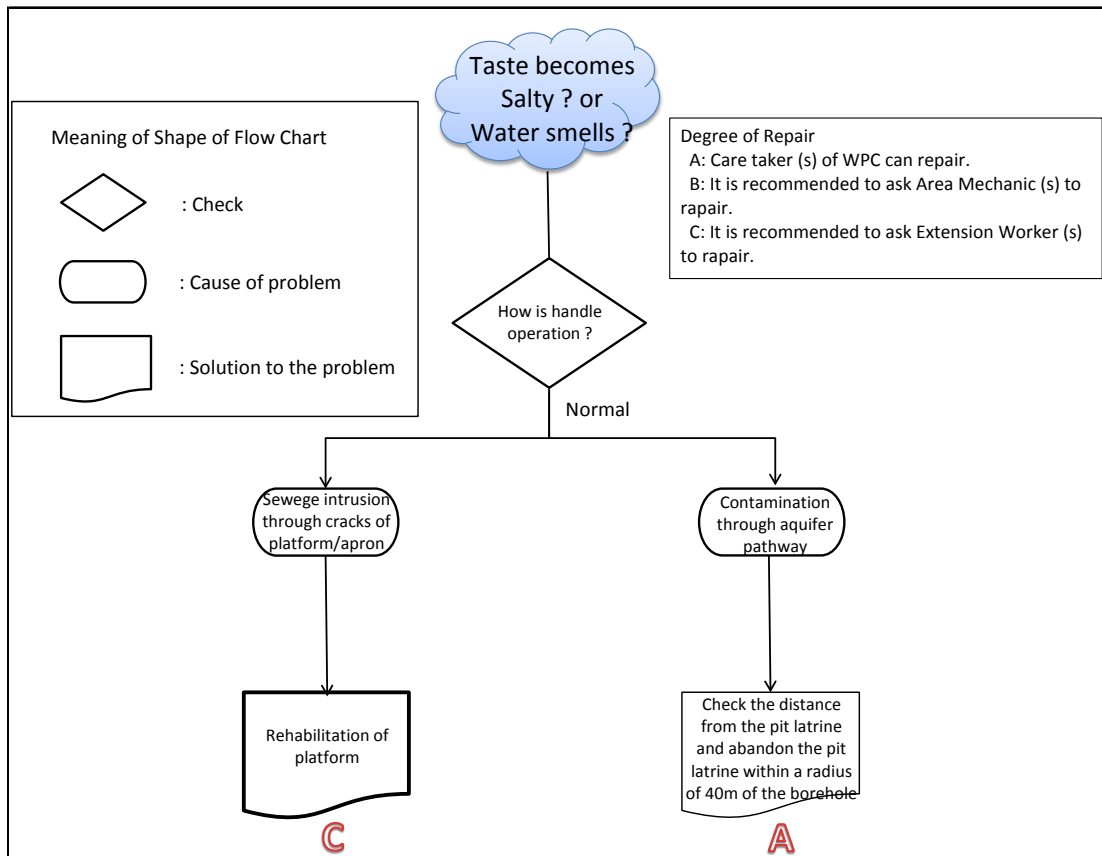
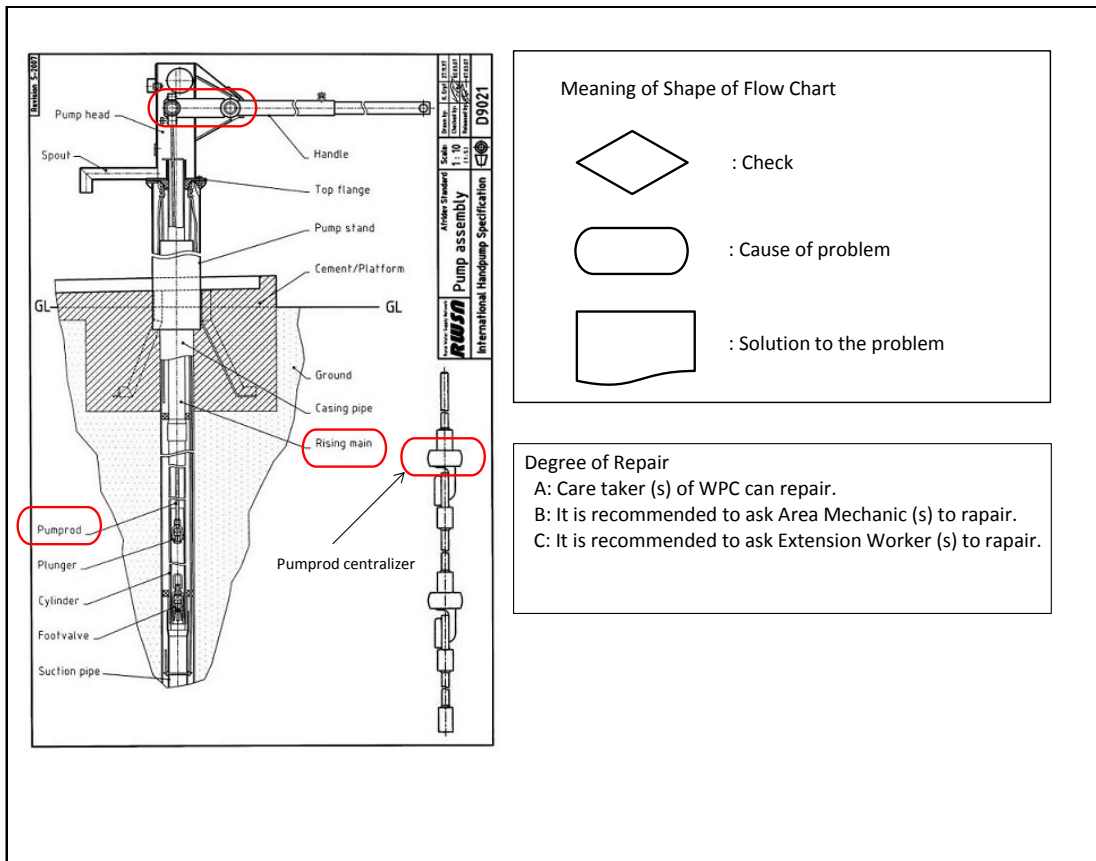
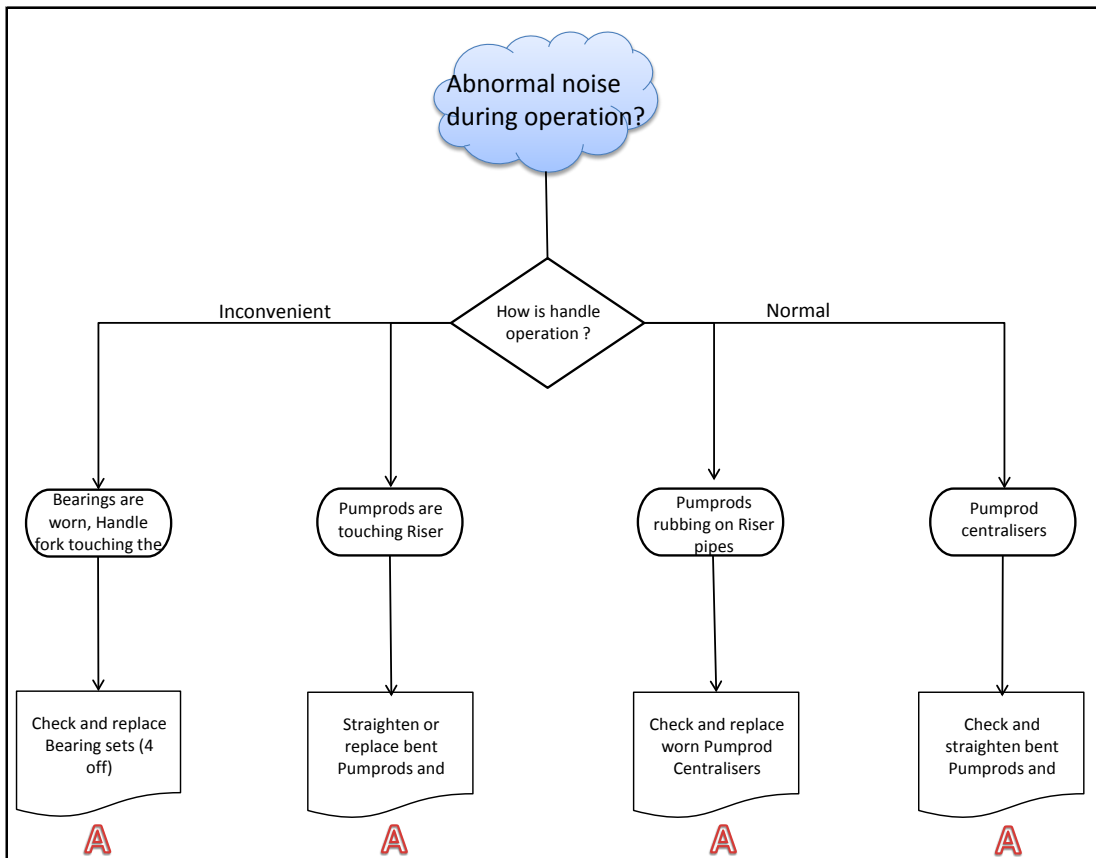

Table 12: Trouble shooting chart 6 (Abnormal noise during operation)



Meaning of Shape of Flow Chart

- : Check
- : Cause of problem
- : Solution to the problem

Degree of Repair

- A: Care taker (s) of WPC can repair.
- B: It is recommended to ask Area Mechanic (s) to repair.
- C: It is recommended to ask Extension Worker (s) to repair.

Table 13: Trouble shooting chart 7 (Pump handle shake)

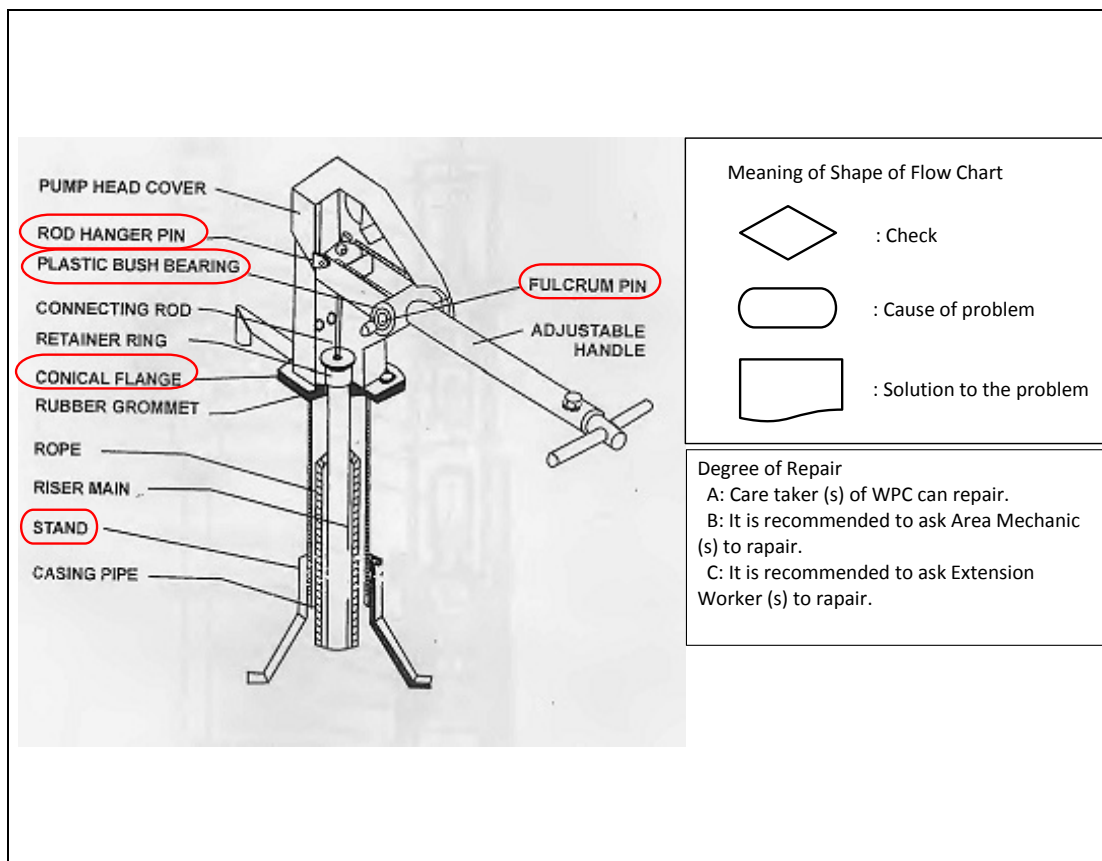
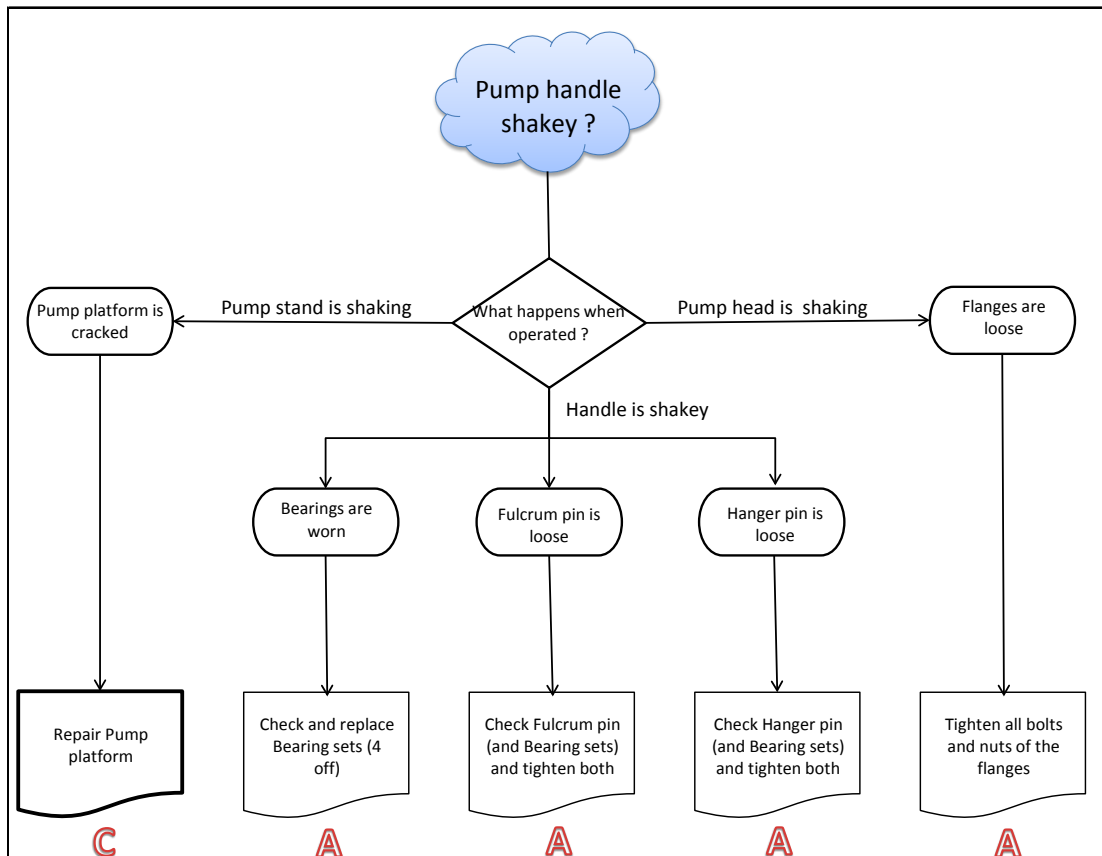

5.2 Identify fast wearing parts and their effects in pump operation

It is the duty of AMs to advise communities that it is cheaper to replace the fast wearing parts than to allow effects of the worn parts to damage more expensive parts.

Fast wearing parts;

- Bush bearings
- U-seal
- O-ring
- Bobbin
- Cup seal
- Rod centralizer

5.3 Identification of problems in the rising main

Possible reasons of problems of the rising main are as follows:

- Leakage at joints due to poor practice when making joints
- Perforations made on pipe due to rubbing with rods or worn out centralisers
- Cracks in pipe

Section 6: Repairing rising main

This section is re-edited based on “**Training manual for area mechanics (Improved CBM2 by GITEC) of Implementation Guide Manual for Establishment of Area Mechanics Revised Draft, November 29, 2006, Ministry of Irrigation and Water Development**”.

The repair and replacement of the internal components of the hand pump are dealt with in the “SKAT/HTN manual and Community Handbook on Water and Sanitation Afridev version”.

Other more advanced repairs will usually necessitate the removal of the rising main.

The rising main will need to be removed if:

- There is excessive leakage that cannot be attributed to a leaking foot valve bobbin or “O” ring.
- Items have been dropped or have jammed inside the rising main that cannot be fished out.
- The cylinder is suspected of needing replacement.
- The riser pipes are disconnected.

Traditionally when the rising main was removed it was cut into manageable lengths, a maximum of 2 lengths (6m), which meant that a large number of joints had to be re-made upon replacement. In addition suitable double sockets were not available and joints were formed by warming the PVC pipes in a fire. It is very important that joints in the PVC rising main are correctly made to ensure a sustainable long-term repair.

To minimise the number of joints that need to be made during a repair the rising main is removed from the borehole in one length without making any cuts. The problem is identified and repaired before replacing the rising main back in the borehole, once again in one length.

During removal of the rising main in one length the joints will come under considerable stress. This procedure should only be attempted if it is known that the uPVC joints were correctly made in accordance with “**6.3.2 Making joints**” during the installation. Otherwise there is a danger that a joint may break and could cause injury.

In addition to the tools needed for pump repair the additional resources needed to withdraw the rising main are:

- At least 8 people, preferably including all or some of the pump caretakers.
- *It is recommended that more people should be available.*

- Poles with forked ends. The number should equal the number of rising mains in the installation. Four should be 3.5m long, the rest should be 4m long.
- A guide rope at least 10m long.

A cleared area long enough to accommodate the rising main so that it may be laid down without delay after withdrawal.

6.1 Removing and replacing of the rising main

The procedure is as shown below.

Table 14: the procedure for removing and replacing of the rising main

Step	Activity	Note / Photo
1	Remove the foot valve.	<i>This may not be possible if there are components stuck inside the rising main. It is still possible to remove the rising main in one piece but extra care must be taken as the weight of water and components will make the control of the rising main as it comes out of the borehole much more difficult.</i>
2	Remove the pump head	-
3	Tie the guide rope to the cone plate.	-
4	Start to pull the rising main of the borehole by pulling the two ends of the support rope and the pipe. The guide rope is used to control the free end of the pipe	<i>The support rope should have knots made on both sides to coincide with the top of the rising main pipe before pulling out the rising main. These marks can be used to check if the rising main length has been changed during repairs.</i>
5	As the rising main comes out of the borehole start to bend it in the direction chosen for it to be laid down. Using the short forked poles start to take the weight of the pipes at the same time keeping the radius of the bend as long as possible.	
6	As the pipe is pulled out the longer forked poles are used to support the free end of the pipe which should be kept up and the pipe horizontal so that the bend is at least three pipes long. If it has not been possible to remove the foot valve, the open end of the pipe should be lowered just enough to	<i>There is a minimum of one forked stick per length of rising main. The radius of curvature is kept as long as possible. The section of pipe already extracted, on the left in the photo below, is kept horizontal and curvature is spread over at least three pipe lengths. Additional support is given to the pipes being bent. Leaking and broken parts should be marked as</i>

Step	Activity	Note / Photo
	<p>drain the water out so that the weight is reduced. The shorter poles at the borehole end of the pipe need to be held off the ground to allow them to be moved easily along the line of removal. The longer poles in the middle and the free end can be allowed to rest on the ground to take the weight and stabilise the pipe.</p>	<p><i>the rising main is being removed.</i></p> 
7	<p>If at any time a joint appears to be weak (e.g. there is evidence of burning as in a homemade joint) the pipe should be carefully supported and cut at the suspect joint. Do not try to bend a weak joint.</p>	-
8	<p>When the cylinder and suction pipe are reached they are carefully withdrawn, making sure to maintain control of the whole pipe. The whole pipe length can now be laid down.</p>	<p><i>Select a suitable place to lay down the pipes and carefully examine the rising main for damage and signs of leaking</i></p>
9	<p>After the necessary repairs have been carried out the whole length of pipe must be carefully cleaned before replacement. Before replacing the pipe the borehole should be sterilised using at least 250 grams (for the average depth of boreholes in Malawi) of high test hypochlorite (HTH). At the very least all down hole components must be thoroughly cleaned.</p>	-
10	<p>The pipe is then replaced in the reverse procedure of removal. Some difficulty may be experienced inserting the cylinder and suction pipe, as some force has to be applied to bend the pipe sufficiently to insert it into the borehole.</p>	-

6.2 Repairing of the rising main

Unless an obstruction can be removed by tipping the pipe up, which is very unlikely, or there is leakage from a joint that can be reconnected, it will be necessary to cut the rising main.

The choice of where to cut depends upon the repair that needs to be carried out. If there is a hole in the pipe, which may be caused by the internal rubbing of a rod joint because rod centralisers have not been replaced when worn, the pipe will need to be cut in two places one on each side of the hole. If the problem only requires access to the inside of the rising main or cylinder, such as the removal of an obstruction, then the pipe only needs to be cut in one place. The location of the cut depends upon the problem to be resolved.

The overall length of the rising main must not be changed. It is very important that the timing of the pump is not changed, i.e., the lengths of the pipes and of the rods are not changed.

All joints must be made using a “Double Socket”. A Double Socket is a straight piece of pipe 230 mm long with an internal diameter that just fits over the outside of the rising main pipe. Each end of the pipe at the joint must be marked at 115 mm to ensure that the double socket is equally distributed over the joint. The joining of PVC pipe should be done in accordance with “6.3.2 Making joints”.

If a length of pipe has had to be cut out, for example if it has a hole in it, it must be replaced by a pipe of equal length and two double socket joints made. The shortest length of a repair should be 300mm to ensure that the joints on each side are adequate. Do not be tempted to make a patch with a piece of pipe and stick it on using solvent cement. It will not last and the rod centraliser will be quickly damaged as it rubs past the inside of the hole.

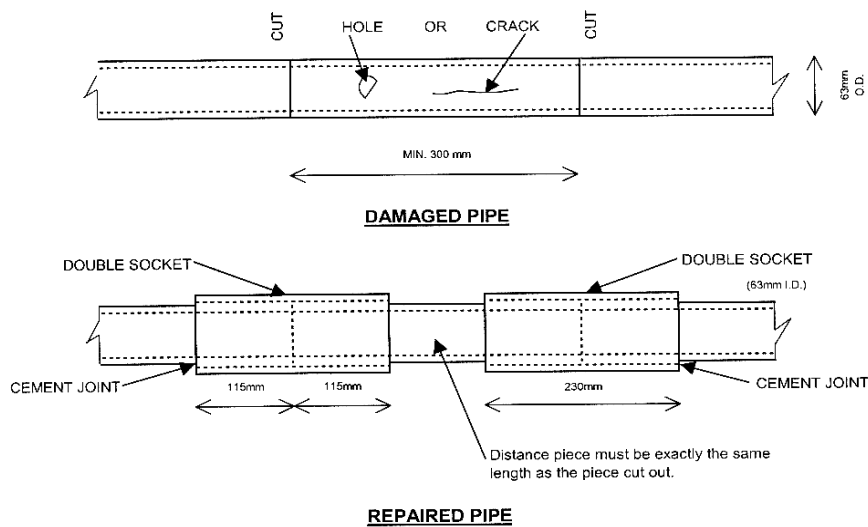

Figure 2: Typical pipe repair

6.3 Making joints on the rising main

6.3.1 Tools and materials



Before making joints on the rising main the tools and materials mentioned below should be prepared:



- a) A hacksaw with spare blades
- b) A measuring tape and marker
- c) Solvent cement
- d) Cleaning fluid
- e) File
- f) Sandpaper
- g) Cloth

6.3.2 Making joints

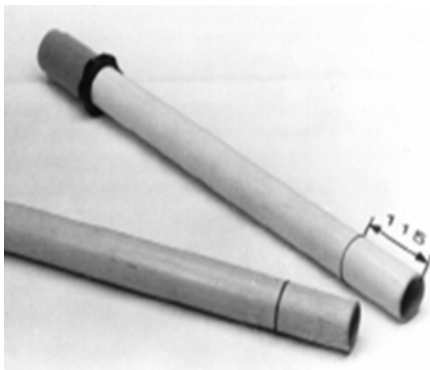
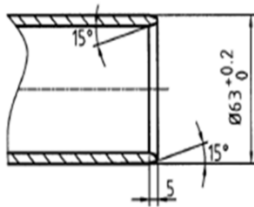
The procedure is as shown below.

Table 15: The procedure for making joints

Step	Activity	Note / Photo
1	Mark the depth of the socket (115 mm) on the plain end of the pipe. If the mark is removed during cleaning the pipe centralizer can be located at the correct place as a depth gauge.	
2	The outer edge of the plain end should be bevelled at 15° to 20°(if not already done at the factory).	<p>chamfered 5 x 15° (inside and outside) all sharp edges rounded</p>  
3	If a pipe has had to be cut on site during a repair the inner edge of the plain end should also be smoothed and all burrs removed, otherwise the plunger and foot	-

Step	Activity	Note / Photo
	valve may be difficult to remove. In the case of a plunger with a cup seal it may prove impossible to remove all of the burrs.	
4	Clean the pipe (bell end inside and plain end up to 115mm) with cloth and cleaning fluid (Carbon tetra chloride).	
5	Roughen the cleaned surfaces with sandpaper.	
6	Clean again with cleaning fluid.	-
7	Apply solvent cement up to the mark on the outside of the plain end and on the inside of the bell end of the rising main with a brush. Replace the caps tightly on the cleaning fluid and the solvent cement after each use.	<p><i>Care must be taken not to apply too much solvent cement which could weaken the pipe wall by dissolving it. Also a bead of excess dissolved uPVC on the inside of the joint may interfere with the plunger and rod centralizers.</i></p>
8	Insert the plain end into the bell end of the other pipe as quickly as possible. Do not twist or rotate the pipe during insertion. Push hard to make sure that the plain end enters the full length to the mark (or the centraliser).	-
9	Wipe off any excess solvent cement with a cloth.	-
10	Allow to set for at least five minutes. The nylon rope should be anchored during these five minutes.	-
11	Check the mark and ascertain how far the plain end entered the	-

Step	Activity	Note / Photo
	socket.	
12	Lower the pipe into the borehole using the nylon rope.	-
13	Allow pipes to cure for about 24 hours before applying any pressure, i.e., do not use the pump.	-

Section 7: Regular preventive maintenance checks

7.1 Identification of problems in an Afridev hand pump

This section is re-edited based on “**Installation and Maintenance Manual for the Afridev Hand pump, Revision 2-2007, SKAT-RWSN**”.



Problems may be identified during regular preventive maintenance and it will be necessary to diagnose the faults and determine the possible reasons for them.

Preventive maintenance means regular check-up of the hand pump at a fixed time interval and changing of spare parts before they are fully worn.

As an example: if the estimated lifetime of a plunger seal is one year, the plunger seal will be changed after a period of one year even if it is still functional. If during a preventive maintenance check, foot valve leakage is noticed, the caretaker will carry out repairs in the foot valve even though the pump has not broken down.

Such interventions help in preventing the sudden failure of the pump.

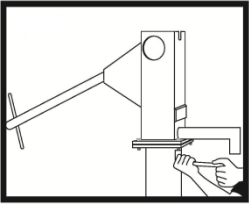
a. Weekly checks:

No.	Item	Illustration
1	Check that the flange bolts and nuts are tight.	
2	Check that the fulcrum pin and hanger pin nuts are tight.	

b. Monthly checks:

No.	Item	Illustration
1	Check if any fasteners or parts in the pump head are missing. If so, replace the parts.	
2	If any unusual noise is noticed, check reason for the same and take corrective actions.	
3	Check if the pump stand is shaky during operation. If yes, the stand is loose in the foundation and contamination of the well can take place. Take corrective measures to repair the foundation.	
5	Carry out a "Leakage Test" as detailed below.	
6	Carry out a "Discharge Test" as detailed below.	

7.2 Leakage test

Leakage test proceed as follows:

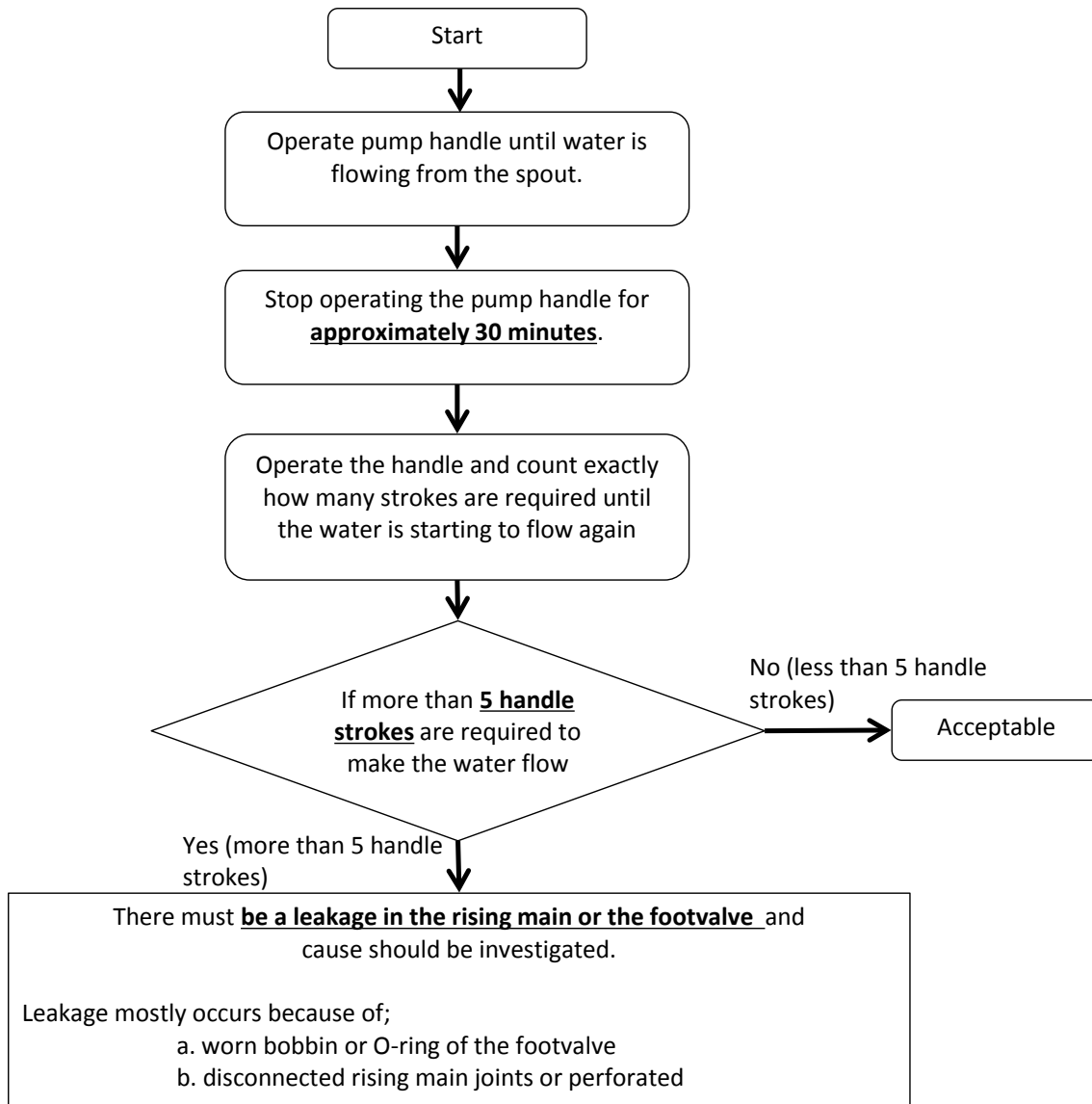

Source: Installation and Maintenance Manual for the Afridev Handpump, Revision 2-2007, SKAT-RWSN

Figure 3: Flowchart for the leakage test

7.3 Discharge test

Discharge test proceed as follows:

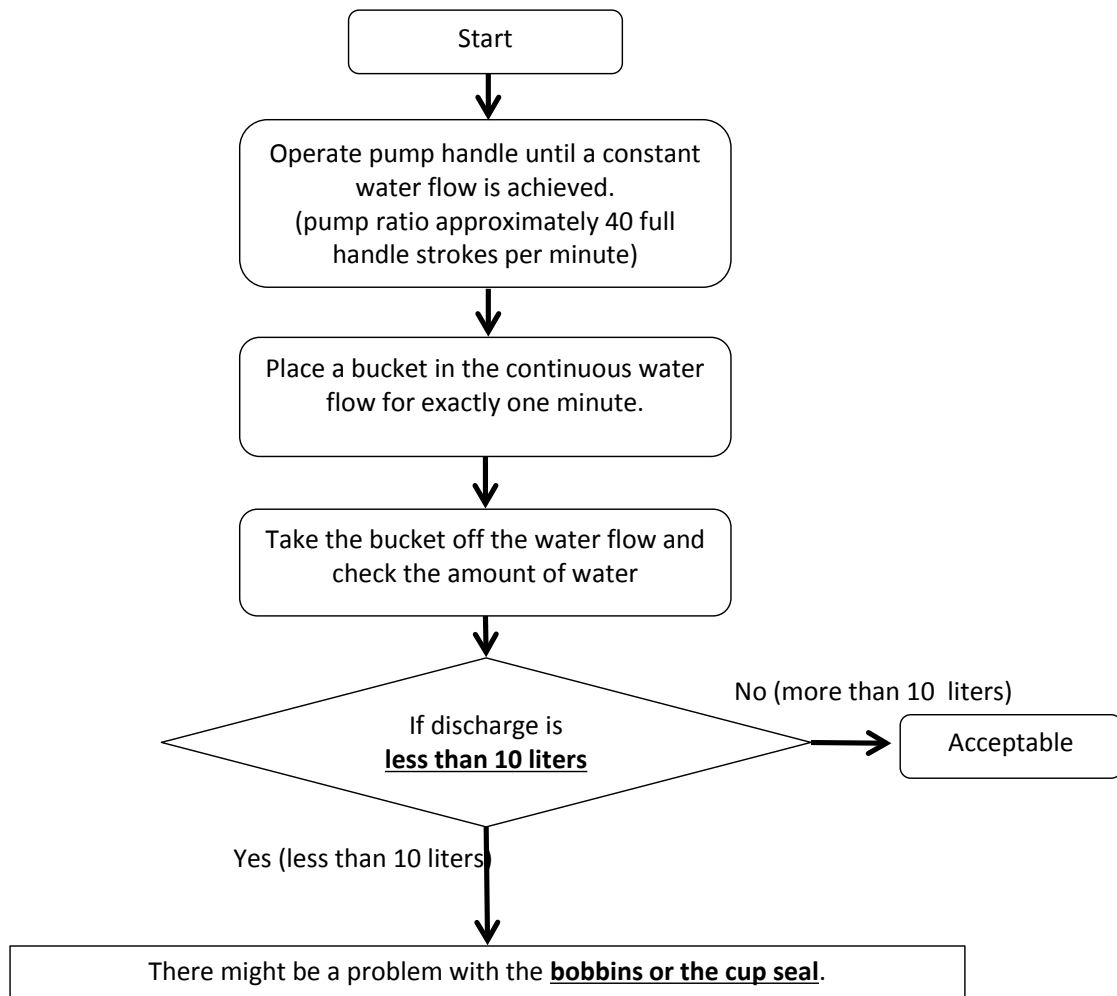

Source: Installation and Maintenance Manual for the Afridev Handpump, Revision 2-2007, SKAT-RWSN

Figure 4: Flowchart for the discharge test

7.4 Records

Any repairs must be recorded in the Water Point Committees (WPCs) record book. Full details of repairs must be entered such as:

- Date of repairs
- Nature of problem(s) encountered
- Parts replaced

- Cost of parts replaced
- Cost of labour
- Who carried out the repairs?

7.5 Fishing

There are times when objects may be dropped or remain inside the rising main causing an obstruction which immobilizes the pump.

It is then necessary to “fish” the objects out. In some cases, items inside the rising main may be extracted by removing the whole rising main and cutting it to gain access to the obstruction.

In other cases something relatively simple can be made by the AM to suit the object causing the obstruction.

For example

Situation of the trouble	Countermeasure
“U”seal has rolled off the plunger and is left in the cylinder or rising main	It may be fished using a simple wire hook on a string.
“U”seal left inside the rising main.	It is important not to try to fish the foot valve. If this is attempted the “U”seal often causes the foot valve to jam inside the rising main necessitating the removal of the rising main with the rods inside.

Some ingenuity is required on the part of the AM to deal with each situation as it arises.

Chapter II Training Module

Module 1: Initial training for Area Mechanics

Module No.	1	
Module Name	Initial training for Area Mechanics	
Target	Newly recruited Area Mechanics (AMs)	
Objectives	<ul style="list-style-type: none"> • To develop the AM's awareness as an entrepreneur to support sustained O&M in rural water supply • To learn ways of approaching the community • To understand contracting procedures with Water Point Community • To remind names and functions of Afridev pump parts • To remind dismantling and re-assembling of Afridev pump • To understand trouble and diagnosis of Afridev pump • To understand repairing rising main • To understand preventive maintenance checks 	
Possible trainers	EWTs (WMAs, HSAs and CDAs)	
Total Duration	Five (5) day course	
Manuals to be used	<ul style="list-style-type: none"> • Training Manual for Area Mechanics • COMMUNITY HANDBOOK ON WATER AND SANITATION AFRIDEV VERSION (SECTION 4 AFRIDEV HANDPUMP MAINTENANCE) • CBM (O&M Refresher Course) Training Manual 	
Other tools / materials to be used	Flip charts, marker pens, drawing showing a borehole, page showing parts and function, parts of Afridev hand pump, flat spanner, socket spanner, fishing tool, hacksaw with spare blades, measuring tape, solvent cement, cleaning fluid (HTH), file, sandpaper, cloth, double end socket, PVC pipe, forked pole, forms and lists	
No.	Session	Activity
1	Introduction to the training of Area Mechanics	Plenary session and focus group discussion
2	Necessary software skills for Area mechanics	Plenary session and focus group discussion
3	Afridev hand pump parts and function	Lecture used visual aids and focus group discussion Demonstration

4	Dismantling and reassembling pump	Practical session and plenary session at the waster point
5	Trouble shooting and diagnosis of Afridev hand pumps	Plenary discussion Lecture using visual aids and focus group discussions
6	Repairing rising main	Lecture using visual aids and demonstration at the water point
7	Repairing rising main by participants	Practical session and plenary session
8	Regular preventive maintenance checks	Plenary session Focus group discussion and demonstration at the water point
9	Question and answer session on technical aspects of the training, Materials/tools to be related to Area Mechanic activity, Spare parts procurement	Plenary session Focus group discussion

Session No. 1 (M1-S1)

Module No. / Title	1/ Initial training for Area Mechanics
Session No. 1	Introduction to the training of Area Mechanics
Appropriate Facilitator Background	Experts in training, having knowledge and skills in participatory development, O&M of rural water supply, etc.
Objectives	<ul style="list-style-type: none"> • To allow participants to get to know each other, settle down and gain confidence • To orient participants to understand the training objectives and know their roles in the community
Expected Outputs	<ul style="list-style-type: none"> • Participants understand the training objectives • Participants know AM's roles in the community
Timing / duration	2 hours on DAY 1
Appropriate Venue	Medium size conference room. Well ventilated room equipped with mobile chairs. Sitting in circular form so that every participant is visible to one another
Methodology	Plenary session and focus group discussion
Materials required	Flip chart and flip chart stand, marker pens
Handouts	Training Manual of Area Mechanics
Session Steps	
Step 1: Introduction and setting the stage	<p><i>Facilitator asks one participant to open the session and allow participants to introduce themselves and the position they hold.</i></p> <p>1. The facilitator will ask participants to:</p> <ol style="list-style-type: none"> 1) Self-introductions 2) Elect their leaders 3) Discuss the timetable <p>2. Ask participants to get into groups to do the following:</p> <ol style="list-style-type: none"> 1) Write their expectations 2) Write their fears 3) Why do they want to be trained in pump maintenance? <p><i>In plenary discuss what they have written. The facilitator will address the issues through discussion with the participants.</i></p>
Step 2: Background to Community Based Management	<i>The facilitator reminds participants of CBM in plenary session.</i>

<p>Step 3: Understand the training objectives and know AM's roles in the community</p>	<p><i>The facilitator will ask participants to get into groups to discuss the following questions and later compare the answers with answers from the facilitator in the plenary session.</i></p> <ul style="list-style-type: none"> a. Objectives of the training b. What are differences between caretaker's repair skills and AM's repair skills? c. Duties of an AM
<p>Notes for facilitators</p>	
<p> </p>	
<p>Attached materials</p>	<p>Annex 1:</p>
<p> </p>	<p>Annex 2:</p>

Session No. 2 (M1-S2)

Module No. / Title	1/ Initial training for Area Mechanics
Session No. 2	Necessary software skills for Area Mechanics
Appropriate Facilitator Background	Experts in training, having knowledge and skills in participatory development, O&M of rural water supply, etc.
Objectives	<ul style="list-style-type: none"> • To show participants how to establish trust with the community • To raise awareness of participants as entrepreneurs • To understand the contract between AM and community
Expected Outputs	<ul style="list-style-type: none"> • Awareness as an entrepreneur
Timing / duration	2 hours on DAY 1
Appropriate Venue	Medium size conference room. Well ventilated room equipped with movable chairs. Sitting in circle so that every participant can see each other.
Methodology	Plenary session and focus group discussion
Materials required	Flip chart and flip chart stand, marker pens
Handouts	Training Manual of Area Mechanics
Session Steps	
Step 1: Establishment of trust with the community	<p><i>The facilitator will ask participants to get into groups to discuss the following questions and later compare the answers with answers from the facilitator in plenary session.</i></p> <ul style="list-style-type: none"> a. How to enhance dialogue with the community? b. How to assure communities that you listen and will address their concerns?
Step 2: Conflict management and problem solving	<p><i>The facilitator will ask participants to get into groups to discuss the following questions and later compare the answers with answers from the facilitator in plenary session.</i></p> <ul style="list-style-type: none"> a. How to respond to difficult behaviour? b. What kind of behaviour worsens the situation?
Step 3: Business management	<p><i>The facilitator will ask participants to get into groups to discuss the following questions and later compare the answers with answers from the facilitator in plenary session.</i></p> <ul style="list-style-type: none"> d. What is business? e. Characteristics of a good and successful AM as an entrepreneur f. Type of records to keep

<p>Step 4: Understanding Contract condition</p>	<p><i>The facilitator will explain the contract between AM and community.</i></p> <ol style="list-style-type: none"> 1) What is a contract? 2) Contents of mention in the contract 3) Type of contract <p><i>Then the facilitator will explain how to fill out the contract form. Later participants will get into groups to fill the information required. In plenary, each group will present its work and correct mistakes made.</i></p>
<p>Step 5: Promotion activities</p>	<p><i>The facilitator will ask participants to get into groups to discuss the following questions.</i></p> <ol style="list-style-type: none"> 1) What are promotion activities? <p><i>Then the facilitator will explain methodology of promotion activities.</i></p>
<p>Step 6: Water Point Sanitation</p>	<p><i>The facilitator will ask participants to get into groups to discuss the following questions.</i></p> <ol style="list-style-type: none"> 1) What is critical point in water point sanitation? <p><i>Then the facilitator will explain the type of sanitary facilities especially fence and soak away pit</i></p>
<p>Notes for facilitators</p>	
<p>Attached materials</p>	<p>Annex 1:</p>
	<p>Annex 2:</p>

Session No. 3 (M1-S3)

Module No. / Title	1/ Initial training for Area Mechanics
Session No. 3	Afridev hand pump parts and functions
Appropriate Facilitator Background	Experts in training, having knowledge and skills in participatory development, O&M of rural water supply, etc.
Objectives	<ul style="list-style-type: none"> To orient participants on what a borehole is To understand how the pump functions
Expected Outputs	<ul style="list-style-type: none"> Understand name of parts and their functions
Timing / duration	2 hours on DAY 1
Appropriate Venue	Medium size conference room. Well ventilated room equipped with movable chairs. Sitting in circle so that every participant can see each other.
Methodology	Lecture using visual aids and focus group discussion, demonstration
Materials required	Drawing showing a borehole, page showing parts and functions, parts of the pump, drawing of foot valve and plunger, cylinder, suction pipe, pail of water
Handouts	Training Manual of Area Mechanics
Session Steps	
Step 1: Name of Afridev hand pump parts	<p><i>The facilitator will ask participants to get into groups to identify parts of the pump on the poster.</i></p> <ol style="list-style-type: none"> Paste a poster showing the Afridev hand pump and ask participants to identify the picture on the poster Hand out the poster and ask participants to label parts of the pump
Step 2: Identify the function of parts	<p><i>The facilitator will ask participants to mention the function of each part.</i></p> <ol style="list-style-type: none"> In plenary each group should present their work and mention the function of each part By way of discussion participants correct group mistakes <p><i>The facilitator will explain that a pump is divided into two categories ABOVE GROUND PARTS and BELOW GROUND PARTS and mention all the parts correctly and explain the function of each part s. (Show the sample of each pump parts</i></p>

<p>Step 3: Understand the functions of pumping</p>	<p><i>The facilitator will demonstrate the functions of pumping</i></p> <ol style="list-style-type: none"> 1) Give out materials to build a complete cylinder 2) Using the complete cylinder built by participants and a pail of water, demonstrate how the pump operates. 3) Simulate different case scenarios using damaged bobbins, foot valve, u-seal or O-ring. <p><i>The facilitator will explain to the participants the situation of pumping that cause damage to pump parts.</i></p>
<p>Notes for facilitators</p>	
<p>Attached materials</p>	<p>Annex 1:</p> <p>Annex 2:</p>

Session No. 4 (M1-S4)

Module No. / Title	1/ Initial training for Area Mechanics
Session No. 4	Dismantling and reassembling pump
Appropriate Facilitator Background	Experts in training, having knowledge and skills in participatory development, O&M of rural water supply, etc.
Objectives	<ul style="list-style-type: none"> To determine participant's technical aptitude in repair skills as a caretaker
Expected Outputs	<ul style="list-style-type: none"> Refresh technical aptitude in repairs as caretaker
Timing / duration	4 hours on DAY 2
Appropriate Venue	Water point which is near to the conference room for plenary session
Methodology	Practical session and plenary session at the water point
Materials required	Flat spanner, socket spanner, fishing tool and pail
Handouts	<ul style="list-style-type: none"> Training Manual of Area Mechanics COMMUNITY HANDBOOK ON WATER AND SANITATION AFRIDEV VERSION, SECTION 4 AFRIDEV HANDPUMP MAINTENANCE
Session Steps	
Step 1: Revision of day 1 material	<i>The facilitator will start with a recap of DAY 1 session with emphasis on sessions 2 and 3.</i>
Step 2: Dismantling pump	<p><i>The facilitator will divide participants into two groups to dismantle and reassemble the pump. This activity will be done without intervention from the facilitator.</i></p> <p><i>The facilitator will observe that all necessary steps are being followed as mentioned in the training manual for AMs, in the process recording weak points and strong points for each group.</i></p>
Step 3: Reassembling pump	<i>When the pump is reassembled and water does not come out, the facilitator will ask participants to discuss and find reasons why this is the case.</i>
Notes for facilitators	
Attached materials	Annex 1:
	Annex 2:

Session No. 5 (M1-S5)

Module No. / Title	1/ Initial training for Area Mechanics
Session No. 5	Trouble shooting and diagnosis of Afridev hand pumps
Appropriate Facilitator Background	Experts in training, having knowledge and skills in participatory development, O&M of rural water supply, etc.
Objectives	<ul style="list-style-type: none"> • To allow participants to know how to diagnose faults and competently make repairs to the WP • To allow participants to know they can identify worn out parts so that they can accordingly advice community and do timely repairs on the WP • To allow participants to make a diagnosis of problems of the rising main
Expected Outputs	<ul style="list-style-type: none"> • Master diagnosis of faults and competently make repairs to the WP
Timing / duration	3 hours on DAY 2
Appropriate Venue	Medium size conference room. Well ventilated room equipped with movable chairs. Sitting in circle so that every participant can see each other.
Methodology	Plenary discussion, Lecture using visual aids and focus group discussion
Materials required	Flip chart and flip chart stand, marker pens, old and damaged u-seals, bush bearings, o-rings, cup-seals, rod centralizer
Hand-outs	Training Manual of Area Mechanics
Session Steps	
Step 1: Trouble shooting	<p><i>The facilitator will ask to get into groups to discuss the following questions</i></p> <ol style="list-style-type: none"> 1) Give possible cause(s) of the problem(s) 2) How can they solve the problem? <p><i>In plenary the facilitator will make/add other possible problems and remedies as mentioned in the training manual for AMs</i></p>
Step 2: Identify fast wearing parts and their effects on pump operation	<p><i>The facilitator will ask to get into groups to discuss the following questions</i></p> <ol style="list-style-type: none"> 1) Write symptoms of the worn out parts 2) Give long time effects of the worn out parts on good pump operation <p><i>In plenary participants will compare and discuss their findings</i></p>

<p>Step 3: Identification of problems in the rising main</p>	<p><i>The facilitator will ask to get into groups to discuss the following questions and later compare the answers with answers from the facilitator in plenary session.</i></p> <ol style="list-style-type: none"> 1) Mention possible reasons of problems of a rising main 2) Signs of problems with rising main <p><i>To summarise the facilitator will explain that before concluding that the problem is due to rising main, the operation of the U-seal, O-ring, Cup seal and bobbin must be checked.</i></p> <p><i>Participants should explain the importance of fitting rod centralizers on the entire length of the pump rods.</i></p>
<p>Notes for facilitators</p>	
<p>Attached materials</p>	<p>Annex 1:</p> <p>Annex 2:</p>

Session No. 6 (M1-S6)

Module No. / Title	1/ Initial training for Area Mechanics
Session No. 6	Repairing rising main
Appropriate Facilitator Background	Experts in training, having knowledge and skills in participatory development, O&M of rural water supply, etc.
Objectives	<ul style="list-style-type: none"> To allow participants gain practical knowledge on best practices in repairing rising main
Expected Outputs	<ul style="list-style-type: none"> The acquirement of the repair techniques of the pipe
Timing / duration	6 hours on DAY 3
Appropriate Venue	WP which was diagnosed as being a delayed discharge water
Methodology	Lecture using visual aids and demonstration
Materials required	Flip chart and flip chart stand, marker pens, flat spanner, socket spanner, fishing tool, double end socket, rising main pipes (damaged sample of rising main), pail, guide rope, forked poles, hacksaw with spare blades, measuring tape, solvent cement, cleaning fluid, sandpaper, cloth
Hand-outs	Training Manual of Area Mechanics
Session Steps	
Step 1: Revision of DAY 2 materials	<p><i>Practical demonstration session of major repairs in the field.</i></p> <p><i>The facilitator will start with a recap of DAY 2 sessions with emphasis on sessions 4 and 5.</i></p> <p><i>Emphasis should be made on session 5 as it links with session 6 on DAY 3</i></p>
Step 2: Facilitators instruction	<p><i>The facilitator will explain best procedures to be followed as mentioned in the training manual for AMs.</i></p> <p><i>The facilitator should explain that removing the rising main is a major operation and should be done as a last resort. And explain that a double check of the condition of all below components should be done before resorting to removing pipes</i></p>
Step 3: How to remove and replace rising main	<p><i>The facilitator will demonstrate how to remove and replace rising main as mentioned in the training manual for AMs</i></p> <p><u>Important notes:</u></p> <ol style="list-style-type: none"> 1) Make sure that everything is ready to avoid delay when applying solvent cement 2) Select a suitable place to lay down the pipes and carefully examine the rising main for damage and signs of leaks. 3) Any damaged length of more than 300 mm should require a section of, or full length of the rising main to be replaced in addition to a double end socket. 4) There may be several damaged sections especially when a pipe or rod centralisers are missing or damaged 5) Fit pipe centralisers at each pipe length and make sure

	<p>pipes are washed before fitting back in the borehole and explain why this should be one.</p> <ol style="list-style-type: none"> 6) Instead of lowering down the whole rising main it is easier to reconnect the rising main in sections on the pedestal (<i>demonstrate this aspect for participants to see</i>) 7) Finally explain again how to check length of rising main using knots made on the safety rope (any length above 30 mm on top of rising main, should be cut by the same length and a new collar fitted) 8) Use more people to hold up the pipe in addition to the rope on the rising main
<p>Step 4: Making joints on the rising main</p>	<p><i>The facilitator will demonstrate how to make a good joint as mentioned in the training manual for AMs.</i></p> <p><i>If the pipe goes in '40' mm or less the joint will be weak. In this case cut the pipe where it meets the sockets, and cut back the socket length where the pipe entered and remake the joint. (Recommend joints of between 75 mm – 115 mm)</i></p> <p><i>The facilitator will take lead to discuss with AMs problems encountered during practical session.</i></p>
<p>Notes for facilitators</p>	
<p>Attached materials</p>	<p>Annex 1:</p> <p>Annex 2:</p>

Session No. 7 (M1-S7)

Module No. / Title	1/ Initial training for Area Mechanics
Session No. 7	Repairing rising main by participants
Appropriate Facilitator Background	Experts in training, having knowledge and skills in participatory development, O&M of rural water supply, etc.
Objectives	<ul style="list-style-type: none"> To assess participant's technical aptitude in carrying out rising main repairs
Expected Outputs	<ul style="list-style-type: none"> Degree of aptitude of each area mechanic to carry out rising main repairs
Timing / duration	7 hours on DAY 4
Appropriate Venue	Water point that is diagnosed as having a low discharge volume
Methodology	Practical session and plenary session
Materials required	Flat spanner, socket spanner, fishing tool, double ended socket, rising main pipes, pail, guide rope, forked poles, hacksaw with spare blades, marker pens, measuring tape, solvent cement, cleaning fluid, sandpaper, cloth
Hand-outs	Training Manual of Area Mechanics
Session Steps	
Step 1: Review of session 6	<i>The facilitator will review the best procedures when repairing rising mains to remind participants.</i>
Step 2: Repairing rising main by participants	<p><i>Participants will be asked to demonstrate how to repair a rising main while facilitators will make observations on best procedures against this check list (score out of 10)</i></p> <p>Step 1: mark a length of 115 mm (depth of socket) on plain pipe to check how far the plain end entered the socket after making the first joint</p> <p>Step 2: mark 10 mm from end of pipe and make a chamfer from an outer edge of the pipe (if not factory made) – Demonstrate how to make a chamfer using a hacksaw and a file.</p> <p>Step 3: clean the outside of the plain end, up to the 115 mm mark and inside the bell socket of the other pipe using cleaning fluid</p> <p>Step 4: roughen the cleaned surfaces with sand paper</p> <p>Step 5: use a brush to apply solvent cement or a feather</p> <p>Step 6: apply solvent cement quickly and thoroughly</p>

<p>Step 2: Repairing rising main by participants</p>	<p>Step 7: apply solvent on socket and then plain end up to the 115 mm mark</p> <p>Step 8: immediately push in the plain end into the bell socket in a straight line up to the 115 mm mark and allow <u>FIVE</u> minutes for drying to have a good joint</p> <p>Step 9: wipe out excess solvent with clean cloth</p> <p>Step 10: check the mark and ascertain how far the plain end entered the socket.</p>
<p>Step 3 Removing and replacing the rising main by participants</p>	<p><i>This step will involve participants removing and replacing the rising main. The facilitator will check against the following important aspects of the session (score out of 5)</i></p> <ol style="list-style-type: none"> 1. Remove below ground components to take out water and make the rising main lighter. 2. Selecting a suitable place to lay down the pipes and carefully examine the rising main for damage and signs of leaking. 3. Marking leaking and broken parts as the rising main is being removed. 4. Checking the length of rising main if it has been changed during repairs. 5. Fit pipe centralisers at each pipe length and make sure pipes are washed before fitting back in the borehole and explain why this should be done.
<p>Step 4 Discussion about AM problems encountered during the practical session</p>	<p><i>The facilitator will lead the discussions with AMs on problems encountered during the practical session and together work out ways of dealing with different scenarios.</i></p>
<p>Notes for facilitators</p>	
<p> </p>	
<p>Attached materials</p>	<p>Annex 1:</p> <p>Annex 2:</p>

Session No. 8 (M1-S8)

Module No. / Title	1/ Initial training for Area Mechanics
Session No. 8	Regular preventive maintenance checks
Appropriate Facilitator Background	Experts in training, having knowledge and skills in participatory development, O&M of rural water supply, etc.
Objectives	<ul style="list-style-type: none"> To allow participants to gain practical knowledge on regular preventive maintenance checks
Expected Outputs	<ul style="list-style-type: none"> The acquisition of knowledge on regular preventive maintenance checks
Timing / duration	4 hours on DAY 5
Appropriate Venue	WP which is near to the conference room for plenary session
Methodology	Plenary session, focus group discussion and demonstration at the water point
Materials required	Flip chart and flip chart stand, marker pens, flat spanner, socket spanner, fishing tool, pail
Hand-outs	Training Manual of Area Mechanics
Session Steps	
Step 1: Identification of problem(s) in an Afridev hand pump	<p><i>The facilitator will ask participants to get into groups to discuss the following questions and later compare the answers with answers from the facilitator in plenary session.</i></p> <ol style="list-style-type: none"> 1) What do you check in a weekly check? 2) What do you check in a monthly check?
Step 2: Leakage test	<p><i>The facilitator will explain the leakage test and demonstrate how to carry out leakage test as mentioned in the training manual for AMs.</i></p> <p><i>The facilitator will ask participants to get into groups to discuss the following questions and later compare the answers with answers from the facilitator in plenary session.</i></p> <ol style="list-style-type: none"> 1) Which parts does the occurrence of leak help to diagnose?
Step 3 Discharge test	<p><i>The facilitator will explain the discharge test and demonstrate how to carry out discharge test as mentioned in the training manual for AMs.</i></p> <p><i>The facilitator will ask participants to get into groups to discuss the following questions and later compare the answers with answers from the facilitator in plenary session.</i></p> <ol style="list-style-type: none"> 1) What is the cause of the poor water quality?

<p>Step 4 Records</p>	<p><i>The facilitator will ask participants to get into groups to discuss the following questions and later compare the answers with answers from the facilitator in plenary session</i></p> <p>1) What records of repairs are kept in the Water Point Committees record book?</p>
<p>Step 5 Fishing</p>	<p><i>The facilitator will explain to participants about fishing of the obstruction in the rising main.</i></p>
<p>Notes for facilitators</p>	
<p> </p>	
<p>Attached materials</p>	<p>Annex 1:</p>
<p> </p>	<p>Annex 2:</p>

Session No. 9 (M1-S9)

Module No. / Title	1/ Initial training for Area Mechanics
Session No. 9	Question and answer session on technical aspects of the training Materials/tools to be related to Area Mechanic activity Spare parts procurement
Appropriate Facilitator Background	Experts in training, having knowledge and skills in participatory development, O&M of rural water supply, etc.
Objectives	<ul style="list-style-type: none"> To equip participants with materials/tools to be related to Area Mechanic activities.
Expected Outputs	<ul style="list-style-type: none"> Establishment of the Area Mechanics
Timing / duration	3 hours on DAY 5
Appropriate Venue	Medium size conference room. Well ventilated room equipped with movable chairs.
Methodology	Plenary session, focus group discussion
Materials required	Flip chart and flip chart stand, marker pens, contract form, quotation form, monthly reporting form, quarterly monitoring form, catchment area list, AM list, spare parts retail shop list, spare parts price list
Handouts	Training Manual of Area Mechanics
Session Steps	
Step 1: Question and answer session on technical aspects of the training	<i>The facilitator will ask participants about questions they have on technical aspects of the training, and answer their questions.</i>
Step 2: Materials/tools to be related to AM activities	<p><i>The facilitator will ask participants to fill in hand-outs of the following:</i></p> <ol style="list-style-type: none"> 1) Contract form 2) Quotation form 3) Monthly reporting form 4) Quarterly monitoring form <p><i>Go through the steps on how to fill in each form.</i></p> <p><i>Later participants will get into groups to fill in the information required.</i></p> <p><i>In plenary, each group will present its work and correct any mistakes.</i></p>

<p>Step 3 Spare parts procurement</p>	<p><i>The facilitator will mention all spare parts retail shops and locations in the district including private suppliers.</i></p> <p><i>The aim is to encourage AMs to play an advisory role to communities on where they can find Afridev spare parts.</i></p> <p><i>AMs should be advised not to interfere in the procurement process so as to build more trust with the Water Point Committees.</i></p> <p><i>Their role should only be to advise on the required spare parts using the quotation book.</i></p>
<p>Step 4 Provide tools and materials</p>	<p><i>The facilitator will provide participants with the following tools and materials:</i></p> <ol style="list-style-type: none"> 1) Socket spanner and flat spanner 2) Fishing tool 3) Standard quotation form 4) Standard contract form 5) AM list 6) Spare parts retail shop list 7) Spare parts price list 8) Monthly reporting form 9) Quarterly monitoring form
<p>Step 5 Distribution of ID cards</p>	<p><i>The facilitator will distribute ID card to each participant with his catchment area list.</i></p>
<p>Notes for facilitators</p>	
<p>Attached materials</p>	<p>Annex 1:</p>
	<p>Annex 2:</p>

Module 2 Refresher training for Area Mechanics

Module No.	2	
Module Name	Refresher training for Area Mechanics	
Target	Area Mechanics who are currently active	
Objectives	<ul style="list-style-type: none"> • To remind the participants on how best they can make good contact with a community • To solve the problems faced by communities • To get new technology on the Afridev hand pump and/or the repair techniques of other types of hand pump • To refresh AMs on special repairs and troubleshooting fundamentals 	
Possible trainers	DWDO and WMAs	
Total Duration	Three (3)-day course	
Manuals to be used	<ul style="list-style-type: none"> • Training Manual for Area Mechanics • COMMUNITY HANDBOOK ON WATER AND SANITATION AFRIDEV VERSION (SECTION 4 AFRIDEV HANDPUMP MAINTENANCE) • CBM (O&M Refresher Course) Training Manual 	
Other tools / materials to be used	Flip charts, flip chart stand, marker pens, sample spare parts, flat spanner, socket spanner, fishing tool, cylinder, u-seal, double end socket, rising main pipe, solvent cement, pipe fishing tools, nylon rope, etc.	
No.	Session	Activity
1	Introduction and setting the stage	Plenary session
2	Community approach refreshed	Focus group discussion and plenary session, practical session
3	Introduction of new technology on the Afridev hand pump and/or lecture of repair techniques of other types of hand pump (i.e. techniques to repair a Malda pump)	Lecture using visual aids and focus group discussion, demonstration
4	Technical refreshment on the Afridev hand pump	Plenary session, demonstration, practical session at the water point

Session No. 1 (M2-S1)

Module No. / Title	2/ Refresher training for Area Mechanics
Session No. 1	Introduction and setting the stage
Appropriate Facilitator Background	Experts in training, with knowledge and skills in participatory development, O&M of rural water supply, etc.
Objectives	<ul style="list-style-type: none"> To allow participants to get to know each other, settle down and gain confidence
Expected Outputs	<ul style="list-style-type: none"> Participants understand the training procedure
Timing / duration	2 hours on DAY 1
Appropriate Venue	Medium size conference room. Well ventilated room equipped with mobile chairs. Sitting in a circle so that all of the participants can see each other
Methodology	Plenary session, focus group discussion
Materials required	Flip chart and flip chart stand, marker pens
Handouts	Training Manual of Area Mechanics
Session Steps	
Step 1: Introduction and setting the stage	<p><i>Facilitator will start by doing the following:</i></p> <ol style="list-style-type: none"> 1) Self introductions 2) Elect their leaders 3) Come up with the timetable
Step 2: Make groups of participants and discussion	<p><i>The facilitator will ask participants to get into groups to discuss the following:</i></p> <ol style="list-style-type: none"> a. Expectations and fears b. Why they wanted to do this refresher course <p>Presentation of the issues from the groups.</p> <p><i>The facilitator will lead the discussion on the issues raised by the participants.</i></p>
Notes for facilitators	
Attached materials	Annex 1:
	Annex 2:

Session No. 2 (M2-S2)

Module No. / Title	2/ Initial training for Area Mechanics
Session No. 2	Community approach refreshed
Appropriate Facilitator Background	Experts in training, with knowledge and skills in participatory development, O&M of rural water supply, etc.
Objectives	<ul style="list-style-type: none"> To remind the participants on how best they can make a good contact with the community To solve the problems faced by communities
Expected Outputs	<ul style="list-style-type: none"> Refresher of the community approach Solution of the problems faced
Timing / duration	4.5 hours on DAY 1
Appropriate Venue	Medium size conference room. Well ventilated room equipped with movable chairs. Sitting in a circle so that all of the participants can see each other. In the field
Methodology	Focus group discussion and plenary session, practical session
Materials required	Flip chart and flip chart stand, marker pens
Handouts	Training Manual of Area Mechanics
Session Steps	
Step 1: Questions to the participants	<p><i>The facilitator will ask participants to get into groups to discuss the following:</i></p> <ol style="list-style-type: none"> How do they enter a community? Who do they make contracts with? What words do they exactly use when communicating with a community?
Step 2: Presentation of the participants	<p><i>Let the participants present their work and let them discuss with the help of the facilitator.</i></p> <p>The help of the facilitator</p> <ol style="list-style-type: none"> For the new village, who do you contact? How many people normally do they meet? How do you introduce yourself to communities? What do you discuss with a community? What questions do communities asked you? What is your aim of visiting a community? What are the problems you face when introducing yourself to a community? What do you tell to a community about your job? Why do communities not honour your contracts? <p><i>The facilitator will then give the following answers.</i></p>

	<ul style="list-style-type: none"> ✓ We need to see the authorities for example the chief, the committee, VDC ✓ Set a good appointment to build good relationships and a friendly atmosphere on your first visit ✓ Try as much as possible to be equal to the community during the discussion ✓ Explain well about your job and how you work independently ✓ Explaining details of your duties <ul style="list-style-type: none"> ▪ Repairing of water points ▪ Advisor to communities on good use of water points ▪ To make quotations on maintenance cost ▪ To report technical problems to the water department ▪ Producing monthly reports, etc. ✓ Before you start conducting any work on the water point ask candidly about the funds that committee has for the following: <ul style="list-style-type: none"> ▪ The purchase spare parts if needed ▪ The payment for your job
<p>Step 3 Lecture about the topic currently faced by a community (i.e. measures to protect hand pumps from theft)</p>	<p><i>The facilitator will ask the participants to get into groups and will give them tasks to come up with methods that can be used to solve problems related to water points.</i></p>
<p>Step 4 Community approach practical</p>	<p><i>Shift to selected community near conference room. Stimulate solution of the problem by AM</i></p>
<p>Step 5 Question from participants</p>	<p><i>The facilitator will ask participants if they have any questions about the content of session 2, and answer their queries.</i></p>
<p>Notes for facilitators</p>	
<p> </p>	
<p>Attached materials</p>	<p>Annex 1:</p>
<p> </p>	<p>Annex 2:</p>

Session No. 3 (M2-S3)

Module No. / Title	2/ Refresher training for Area Mechanics
Session No. 3	<i>Introduction of new technology on the Afridev hand pump and/or lecture of repair techniques of other types of hand pump (i.e. technique to repair a Malda pump)</i>
Appropriate Facilitator Background	Experts in training, with knowledge and skills in participatory development, O&M of rural water supply, etc.
Objectives	<ul style="list-style-type: none"> To acquire new technology on the Afridev hand pump and/or repair techniques on other types of hand pump.
Expected Outputs	<ul style="list-style-type: none"> Acquirement of new technical knowledge for hand pumps
Timing / duration	6 hours on DAY 2
Appropriate Venue	Medium size conference room. Well ventilated room equipped with movable chairs. Selected water points
Methodology	Lecture using visual aids and focus group discussion, demonstration
Materials required	Flip charts, flip chart stand, marker pens, sample pump parts
Handouts	The text which describes the new techniques for hand pumps
Session Steps	
Step 1: Plenary session	<p><i>The facilitator will explain to participants to get into groups to introduce new technology on the Afridev hand pump and/or to learn new techniques for other type of hand pumps.</i></p> <p>(i.e. explanation of Malda pump parts and functions, maintenance, new material)</p>
Step 2: Demonstration	<p><i>Shift selected water point.</i></p> <p><i>The facilitator will demonstrate to enable participants to acquire new techniques for hand pumps.</i></p> <p>(i.e. dismantling and reassembling Malda pump)</p>
Notes for facilitators	
Attached materials	Annex 1:
	Annex 2:

Session No. 4 (M2-S4)

Module No. / Title	2/ Refresher training for Area Mechanics
Session No. 4	Technical refreshment on the Afridev hand pump
Appropriate Facilitator Background	Experts in training, with knowledge and skills in participatory development, O&M of rural water supply, etc.
Objectives	<ul style="list-style-type: none"> To refresh participants on special repairs and troubleshooting fundamentals To allow participants to exercise the skills to conduct special repairs on Afridev hand pumps
Expected Outputs	<ul style="list-style-type: none"> Technical refreshment on special repairs and troubleshooting fundamentals.
Timing / duration	6 hours on DAY 3
Appropriate Venue	Medium size conference room. Well ventilated room equipped with movable chairs. Selected water points
Methodology	Plenary session, demonstration, practical session at the water point
Materials required	Flat spanner, socket spanner, fishing tool, cylinder, u-seal, double end socket, rising main pipe, solvent cement, pipe fishing tools, nylon rope, etc.
Handouts	Training Manual of Area Mechanics, COMMUNITY HANDBOOK ON WATER AND SANITATION AFRIDEV VERSION, SECTION 4 AFRIDEV HANDPUMP MAINTENANCE
Session Steps	
Step 1: Technical refreshment on the Afridev hand pump	<p><i>The facilitator will lead the session by discussing challenges that participants meet when conducting repairs</i></p> <ul style="list-style-type: none"> With series of demonstration on cylinder How to identify problems on the rising main Removing fallen objects (u-seal/cup seal) Rising main – fishing, making joints Rods and timing during the re-installation Measuring water column
Step 2: Fishing the fallen pipe and re-install the pump	<p><i>Shift selected water point.</i></p> <p><i>While in the field the facilitator will allow participants to work in their groups to:</i></p> <ul style="list-style-type: none"> Fishing of the pipes Identify the problems and resolve the problems Re-install the pump

Step 3: Question and answer session on technical refreshment	<i>The facilitator will ask participants questions on technical refreshment, and give them answers.</i>
Step 4: Distribution of ID cards	<i>The facilitator will distribute ID card to each participant.</i>
Notes for facilitators	
Attached materials	Annex 1:
	Annex 2:

Chapter III Training Timetable

Timetable for Area Mechanic Initial Training (Draft)

Time	Activity	Learning Method	Facilitator (S)
DAY 1			
7:30- 8:00am	<ul style="list-style-type: none"> ▪ Take ID photos of the participants 	Digital camera	
8:00- 10:00am	<ul style="list-style-type: none"> ▪ Opening remarks ▪ Introduction and setting the stage <ul style="list-style-type: none"> ❖ Self-introductions and election of leaders ❖ Discuss the timetable ❖ Participants expectations and fears ▪ Background to Community Based Management ▪ Understand the training objectives and learn AM's roles in the community 	Plenary Focus group discussion (FGD)	
10:00-10:15am BREAK			
10:15-12:15pm	<ul style="list-style-type: none"> ▪ Establishment of trust with the community ▪ Conflict management and problem solving ▪ Business management ▪ Understanding contract conditions ▪ Promotion activities ▪ Water point sanitation 	Plenary FGD	
12:15 – 1:00pm LUNCH			
1:00 - 3:00pm	<ul style="list-style-type: none"> ▪ Name of Afridev hand pump parts ▪ Identify the functions of parts ▪ Understand functions of the pumping 	Lecture FGD Demonstration	
3:00- 3:15pm BREAK			
3:15 – 4:00pm	<ul style="list-style-type: none"> ▪ Question time 		
DAY 2			
8:00 – 10:00am	<ul style="list-style-type: none"> ▪ Recap of day 1 ▪ Dismantling pump 	Plenary Practice	
10:00-10:15am BREAK			
10:15-12:15pm	<ul style="list-style-type: none"> ▪ Reassembling pump 	Practice	
12:15 – 1:00pm LUNCH			
1:00- 3:00pm	<ul style="list-style-type: none"> ▪ Trouble shooting ▪ Identify fast wearing parts and their effects in pump operation 	Lecture FGD	
3:00-3:15pm BREAK			
3:15- 4:15pm	<ul style="list-style-type: none"> ▪ Identification of problems in the rising main 	Lecture FGD	
DAY 3			
8:00- 10:00am	<ul style="list-style-type: none"> ▪ Recap of day 2 ▪ Facilitators instruction <ul style="list-style-type: none"> ❖ Best procedures 	Plenary Lecture	

Time	Activity	Learning Method	Facilitator (S)
10:00-10:15am BREAK			
10:15- 12:15pm	▪ How to remove and replace rising main	Demonstration	
12:15 -1:00pm LUNCH			
1:00- 3:00pm	▪ Making joints on the rising main	Demonstration	
3:00 -3:15pm BREAK			
3:15- 4:00pm	▪ Question time	Plenary	
DAY 4			
8:00- 10:00am	▪ Recap of day 3 ▪ Repairing rising main by participants	Plenary Practice	
10:00-10:15am BREAK			
10:15- 12:15am	▪ Repairing rising main by participants	Practice	
12:15 -1:00pm LUNCH			
1:00- 3:00pm	▪ Removing and replacing the rising main by participants	Practice	
3:00 -3:15pm BREAK			
3:15- 4:15pm	▪ Discussion about AMs' problems encountered during the practical sessions	Plenary	
DAY 5			
8:00- 9:00am	▪ Identification of problems in an Afridev hand pump	Plenary FGD	
9:00- 10:00am	▪ Leakage test	FGD Demonstration	
10:00-10:15am BREAK			
10:15- 12:15am	▪ Discharge test ▪ Records of repairs ▪ Fishing of the obstruction in the rising main	FGD Demonstration Plenary	
12:15 -13:00pm LUNCH			
13:00-15:00pm	▪ Questions and answers session on technical aspects of the training ▪ Materials/tools related to AM activities ▪ Spare parts procurement	Plenary FGD	
3:00 -3:15pm BREAK			
3:15- 4:15pm	▪ Provide tools and materials ▪ Distribution of ID cards ▪ Closing remarks	Plenary	

Timetable for Area Mechanic Refresher Training (Draft)

Time	Activity	Learning Method	Facilitator (S)
DAY 1			
7:30- 8:00am	<ul style="list-style-type: none"> ▪ Take ID photos of participants 	Digital camera	
8:00- 10:00am	<ul style="list-style-type: none"> ▪ Opening remarks ▪ Introduction <ul style="list-style-type: none"> ❖ Self-introductions and election of leaders ❖ Discuss the timetable ▪ Make groups of participants for discussions <ul style="list-style-type: none"> ❖ Expectations and fears ❖ Why they wanted this refresher course 	Plenary Focus group discussion (FGD)	
10:00-10:15am BREAK			
10:15-12:15pm	<ul style="list-style-type: none"> ▪ Question to the participants ▪ Presentation of the participants ▪ Lecture about a topic currently facing a community 	Plenary FGD	
12:15 – 1:00pm LUNCH			
1:00 - 3:00pm	<ul style="list-style-type: none"> ▪ Practical community approach 	Practice	
3:00- 3:15pm BREAK			
3:15 – 3:45pm	<ul style="list-style-type: none"> ▪ Question time 		
DAY 2			
8:00 – 10:00am	<ul style="list-style-type: none"> ▪ Recap of day 1 ▪ Learning new techniques for hand pumps 	Plenary Lecture FGD	
10:00-10:15am BREAK			
10:15-12:15pm	<ul style="list-style-type: none"> ▪ Learning new techniques for hand pumps 	Lecture FGD	
12:15 – 1:00pm LUNCH			
1:00- 3:00pm	<ul style="list-style-type: none"> ▪ Demonstration of new techniques for hand pumps 	Demonstration	
3:00-3:15pm BREAK			
3:15- 3:45pm	<ul style="list-style-type: none"> ▪ Question time 	Plenary	
DAY 3			
8:00- 10:00am	<ul style="list-style-type: none"> ▪ Recap of day 2 ▪ Introduction of Afridev hand pumps ▪ Repair of major problems (e.g., cleaning cylinder demonstration) 	Plenary Demonstration	
10:00-10:15am BREAK			
10:15- 12:00pm	<ul style="list-style-type: none"> ▪ Removing fallen objects (u-seal/cup seal) ▪ Rising main – fishing and making joints ▪ Rods and measuring water columns 	Demonstration	
12:15 -1:00pm LUNCH			
1:00- 3:00pm	<ul style="list-style-type: none"> ▪ Afridev practical (selected water point) 	Practice	
3:00 -3:15pm QUICK LUNCH			

Time	Activity	Learning Method	Facilitator (S)
3:15- 4:30pm	<ul style="list-style-type: none">▪ Question time▪ Distribution of ID cards▪ Closing remarks	Plenary	

Appendices



Appendix 1: Sample form for contract³

MGWILIZANO
pakati pa

Numbering

Tsiku: _____

Mudzi / Mfumu yayikulu: _____

Mukonzi wa Dela : _____

Zoneyera kuchita (chongani mu kabokosi) : Mgwirizano Mgwirizano

wapamwezi wapachaka Zina

Mtundu wa ntchito : _____

Malipiro a wokonza wa Dela : K

Zipangizokomwezagulidwa : _____

Zipangizozomwezaikidwa	Mtengo wa zinthu	Zonse
	K	K
	K	K
	K	K
	K	K
	K	K
Zonse pa modzi		K

Wokonza wa Dela

Dzina:

Saini:

OimiraMudzi

Dzina:

Saini:

³Note: This example was provided by InterAide.

Appendix 2: AM Monitoring Checklist⁴

Borehole number:						
Village Name :						
T/A						
District:						
Monitoring Data						
Hand pump is working	Good		Fair		Bad	
Grouting of pedestal or pump stand	Firm		Loose			
No of strokes to fill 20L bucket (Approx. 40 to 50 strokes for well-functioning borehole)			Strokes			
Corrosion of pump stand and head	None		Slight		Bad	
Corrosion of handle parts	None		Slight		Bad	
Condition of plunger set-up	Good		Fair		Bad	
Condition of foot valve set-up	Good		Fair		Bad	
Worn out sealing parts	Bobbin		O-ring		U-seal	
Worn out pump rods	None		Slight		Bad	
Worn out rod centralizers	None		Slight		Bad	
Worn out bush bearings	None		Slight		Bad	
Wear on cylinder liner	None		Slight		Bad	
Why poor performance/ breakdown	No spares		No funds		No skill	
Name of Area mechanic						
Date						
Signature						
Water point committee representative						
Signature						
Date						

⁴SKAT-RWSN 2007: Installation and Maintenance Manual for Afridev Hand pump



Rural Water Supply Operation and Maintenance Series were developed for planners, managers and practitioners for the practices of operation and maintenance of boreholes fitted with Afridev hand pumps in rural Malawi.